

Lance-N-Loc™ Tooling

Standard Punches, Dies, Strippers, & Holders



Lance-N-Loc is a sheet metal clinching system which creates a strong mechanical joint without external fasteners or welding. The metals are lanced and squeezed to form an interlock below the bottom layer of the sheet metal. Lance-N-Loc is good for joining harder materials, multiple layers, and is ideal for use where electrical conductivity is required.



BTM
CORPORATION

www.BTMcorp.com

810-364-4567

Fastening without Fasteners

Lance-N-Loc™ is a sheet metal clinching system which creates a strong mechanical joint without the use of external fasteners or welding. The metals are lanced and squeezed to form an interlock below the bottom layer of the sheet metal.

Lance-N-Loc™ is good for joining harder materials, multiple layers, and is ideal for use where electrical conductivity is required.

The final result is a joint with a greater width than the drawn section of the metals. This accounts for the high strength of Lance-N-Loc™ joints. The entire sequence takes place in a single press stroke.

LANCE-N-LOC™ PROCESS



CLAMPS

The first step in the process involves the clamping of the material with a punch side stripper.

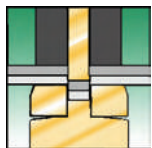

DRAWS

Next, the punch draws the material into the die.

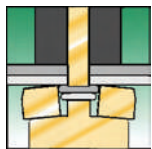

LOCKS

As the material flows into the die, the die blades expand, allowing the metal to flow into a strong interlock below the bottom sheet.

PUNCH SIDE



BUTTON SIDE



Note: Lance-N-Loc™ is not leak proof. See Tog-L-Loc®.

BEFORE YOU ORDER

Follow these steps to ensure your satisfaction with Lance-N-Loc™:

1. Submit a sample of your part and or material to the BTM sample department. A "Sample Data Sheet" will be used to record what tooling was used to make your sample, as well as the resulting shear and peel strengths.
2. Test your sample
3. Upon your approval, contact the BTM application engineering department and we will help you select the correct punch, die, stripper, holders or other production solution. This catalog will be used as a reference.
4. Order the required Lance-N-Loc™ or Tog-L-Loc® tooling for your application.

LANCE-N-LOC™ DIE COMPARISON



940 Series Dies

940 Dies feature a built in die shield that surrounds an elastomeric ring and two die blades.



Two Bladed Elastomer Dies

These dies are ideal when the die guarding can be modified to incorporate contour features in a part.



Two Bladed Dies

Ideal for very tight joining locations up against a flange, where the blades can operate parallel.

SAFETY NOTE

It is the customer and/or user's responsibility to provide proper safety controls and/or guarding when a pinch point is present.

TABLE OF CONTENTS

BALL LOCK PUNCHES

3.0	4
3.8	4
4.6	4

BALL LOCK PUNCH ASSEMBLIES AND HOLDERS

Round Die Set Punch Holder	5
----------------------------------	---

3.0 LANCE-N-LOC™ DIES

940 "MINI" Stepped Short Insert (SSI) Die	6
940 Stepped Short Insert (SSI) Die	6
Style "A" Elastomer Die	7
Short Insert Elastomer Die	7
Style "A" Combo Block Die	8
Combo Block Die	8
Handheld Combo Block Die	8

3.8 LANCE-N-LOC™ DIES

Style "A" Elastomer Die	9
-------------------------------	---

4.6 LANCE-N-LOC™ DIES

Style "A" Elastomer Die	10
Short Insert Elastomer Die	10
Style "A" Combo Block Die	11
Combo Block Die	11

LANCE-N-LOC™ DIE HOLDERS

For Style "A" Elastomer Dies:

3.0 Tooling	12
4.6 Tooling	13

LANCE-N-LOC™ DIE MOUNTING	14-15
---------------------------------	-------

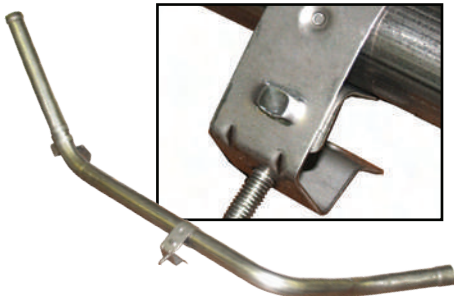

Lance-N-Loc™ Ball Lock Punches

3.0

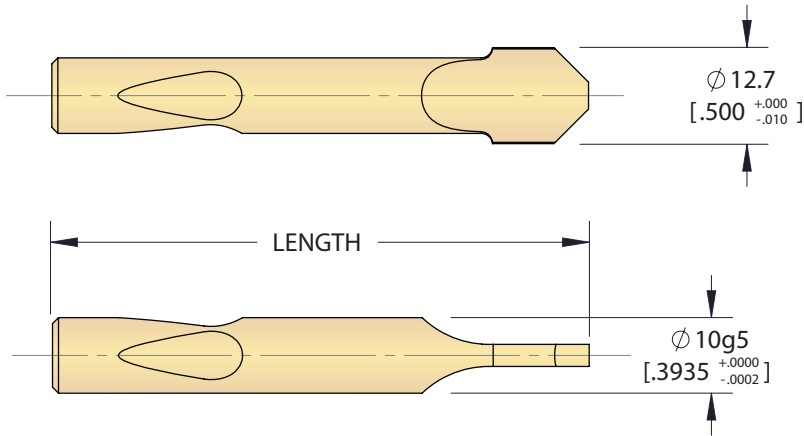

Length		BTM Order No.
mm	in	
71	[2.795]	768501A
80	[3.150]	768501B
90	[3.543]	768501C
100	[3.937]	768501D

3.8

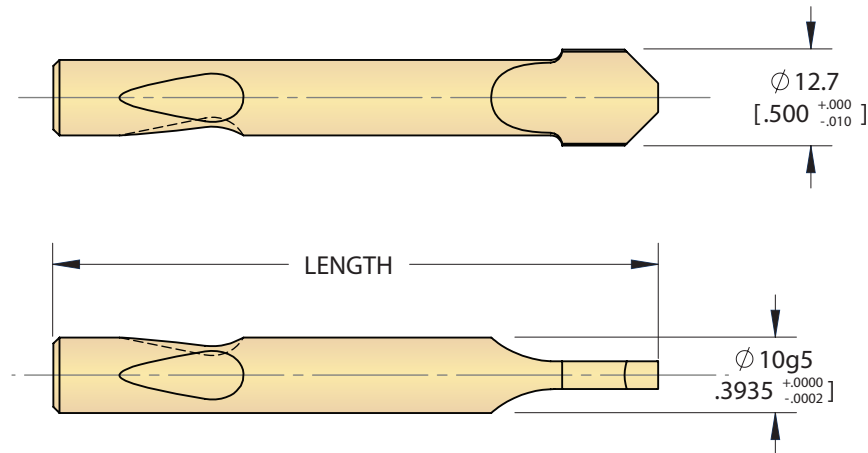

Length		BTM Order No.
mm	in	
71	[2.795]	PD253101A
80	[3.150]	PD253101B
90	[3.543]	PD253101C
100	[3.937]	PD253101D

4.6

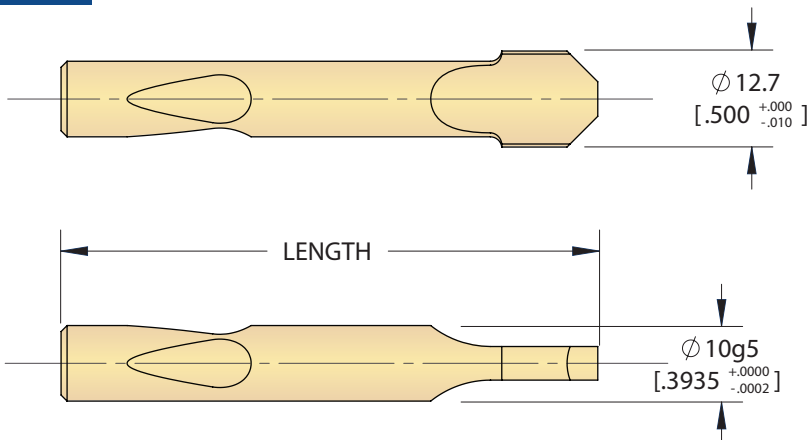

Length		BTM Order No.
mm	in	
71	[2.795]	768601A
80	[3.150]	768601B
90	[3.543]	768601C
100	[3.937]	768601D

Lance-N-Loc™ Round Punch Holder [Die Set Mounting]

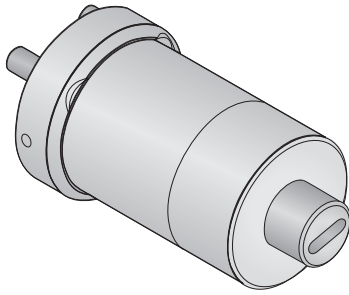

ASSEMBLY INCLUDES:

- ① One (1) Punch Holder
- ② One (1) Stripper Spring
- ③ One (1) Stripper Can
- ④ One (1) Ball & Retaining Spring
- ⑤ Two (2) Dowel Pins
- ⑥ Three (3) Mounting Screws
- ⑦ One (1) Ball Lock Punch
- ⑧ One (1) Stripper Tip

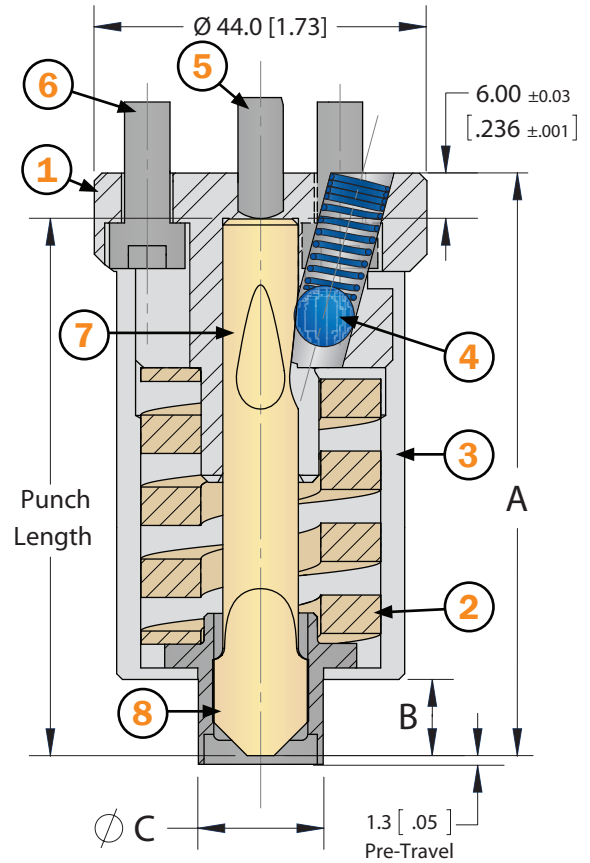

Tooling	Punch Length	A	B	C	BTM No.
3.0	71 [2.795"]	77.0 [3.031"]	10.0 [.39"]	Ø16.5 [.65"]	768500A
	80 [3.150"]	86.0 [3.386"]	19.0 [.75"]		768500B
	90 [3.543"]	96.0 [3.780"]	29.0 [1.14"]		768500C
	100 [3.937"]	106.0 [4.173"]	39.0 [1.54"]		768500D
3.8	71 [2.795"]	77.0 [3.031"]	10.0 [.39"]	Ø19.0 [.75"]	PD253100A
	80 [3.150"]	86.0 [3.386"]	19.0 [.75"]		PD253100B
	90 [3.543"]	96.0 [3.780"]	29.0 [1.14"]		PD253100C
	100 [3.937"]	106.0 [4.173"]	39.0 [1.54"]		PD253100D
4.6	71 [2.795"]	77.0 [3.031"]	10.0 [.39"]	Ø22.2 [.88"]	768600A
	80 [3.150"]	86.0 [3.386"]	19.0 [.75"]		768600B
	90 [3.543"]	96.0 [3.780"]	29.0 [1.14"]		768600C
	100 [3.937"]	106.0 [4.173"]	39.0 [1.54"]		768600D

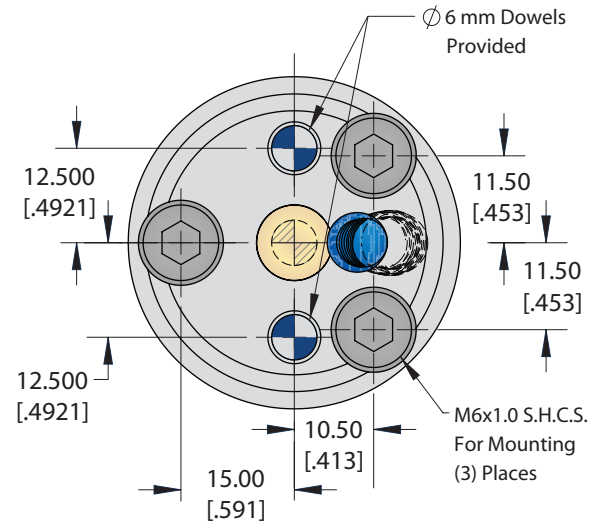

“MINI” Stepped Short Insert (SSI) Die

AD	Standard
.020	797600BE
.025	797600CE
.030	797600DE
.035	797600EE
.040	797600FE
.045	797600GE
.050	797600HE

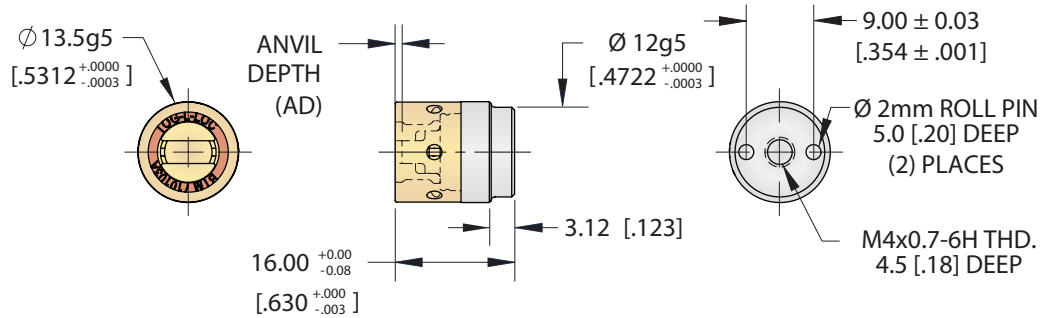

Contact BTM for the maximum total material thickness this die can join.
 Maximum Button Dimension (BD) for this die is 5.3 [.210]

“Mini” dies are used when joining minimum flange widths and total material thickness permits joining with the maximum allowable button dimension (BD). Maximum BD for the mini die is stated.

STANDARD Stepped Short Insert (SSI) Die

AD	Standard
.020	797700BE
.025	797700CE
.030	797700DE
.035	797700EE
.040	797700FE
.045	797700GE
.050	797700HE

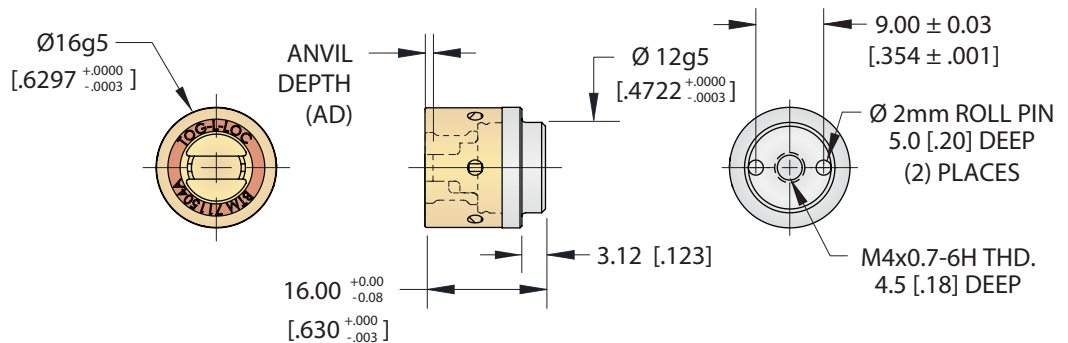

Style “A” die

AD	Standard
.015	016932
.020	013798
.025	013799
.030	013800
.035	013801
.040	013802
.045	013803
.050	013804
.055	016167
.060	016168
.065	016169
.070	016170
.075	017318
.080	017319

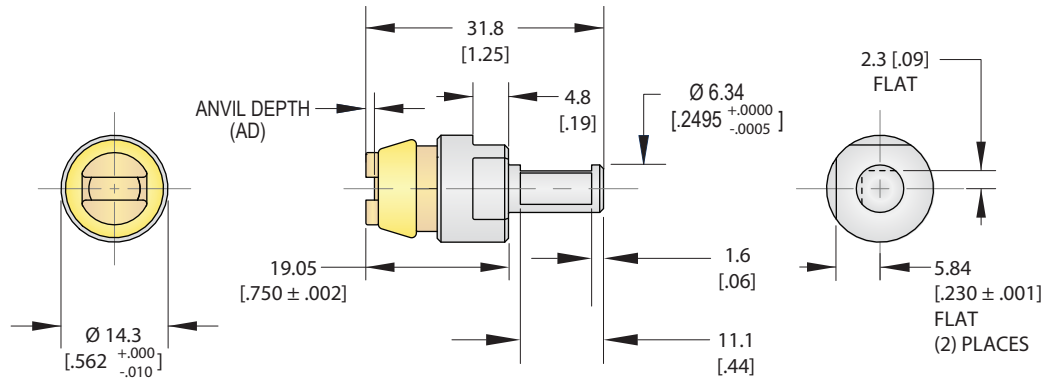

Short Insert die

AD	Standard
.020	013753
.025	013754
.030	013755
.035	013756
.040	013757
.045	013232
.050	013758

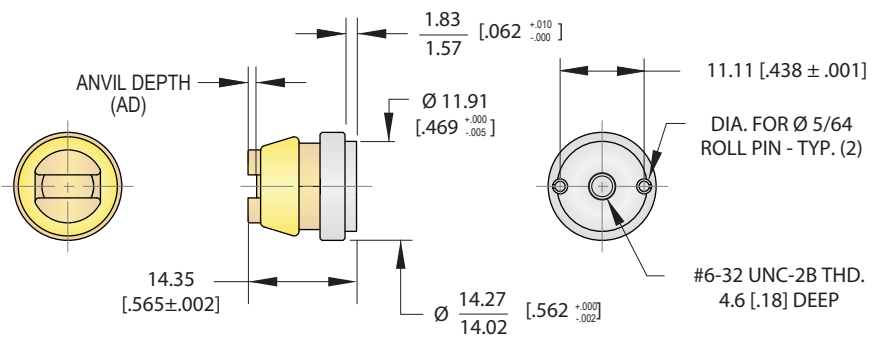

Style “A” die

AD	Standard
.020	PD222900B
.025	PD222900C
.030	PD222900D
.035	PD222900E
.040	PD222900F
.045	PD222900G
.050	PD222900H
.055	PD222900J
.060	PD222900K
.065	PD222900L
.070	PD222900M
.075	PD222900N
.080	PD222900P

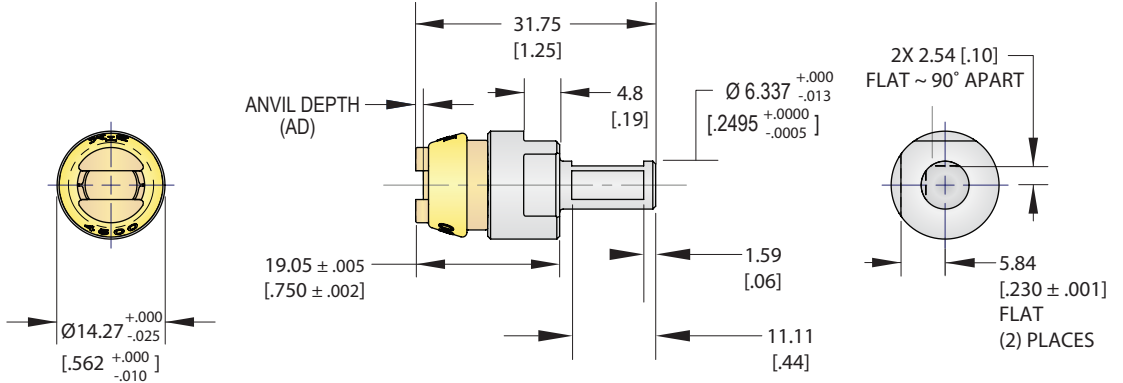

4.6 Lance-N-Loc™ Two Blade Elastomer Dies

Style “A” Die

AD	Standard	AD	Standard
.020	017357	.110	016388
.025	017358	.115	016389
.030	017359	.120	016390
.035	017360	.125	016391
.040	017361	.130	016392
.045	017362	.135	016393
.050	017363	.140	016394
.055	017364	.145	016395
.060	017365	.150	016396
.065	017366		
.070	017367		
.075	016381		
.080	016382		
.085	016383		
.090	016384		
.095	016385		
.100	016386		
.105	016387		

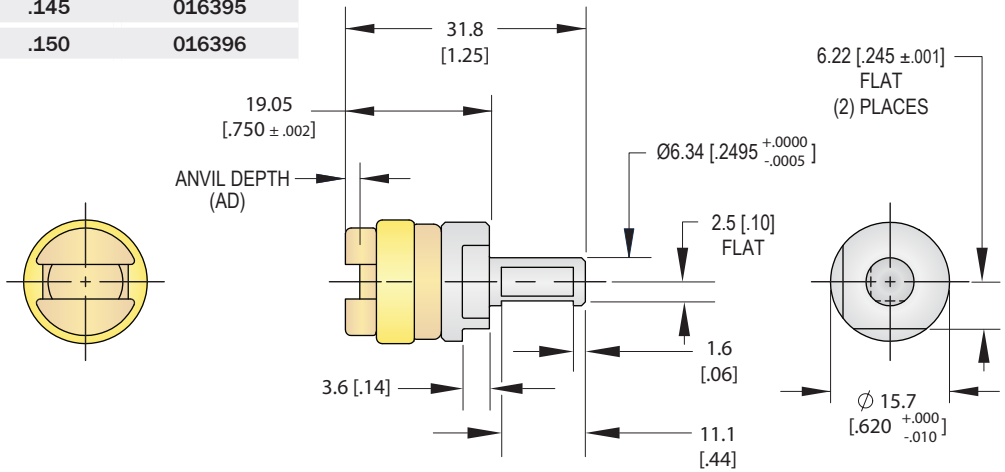

Short Insert Die

AD	Standard
.030	PD225400B
.035	PD225400C
.040	PD225400D
.045	PD225400E
.050	PD225400F
.055	PD225400G
.060	PD225400H
.065	PD225400J
.070	PD225400K
.075	PD225400L
.080	PD225400M
.085	PD225400N
.090	PD225400P
.095	PD225400R
.100	PD225400S

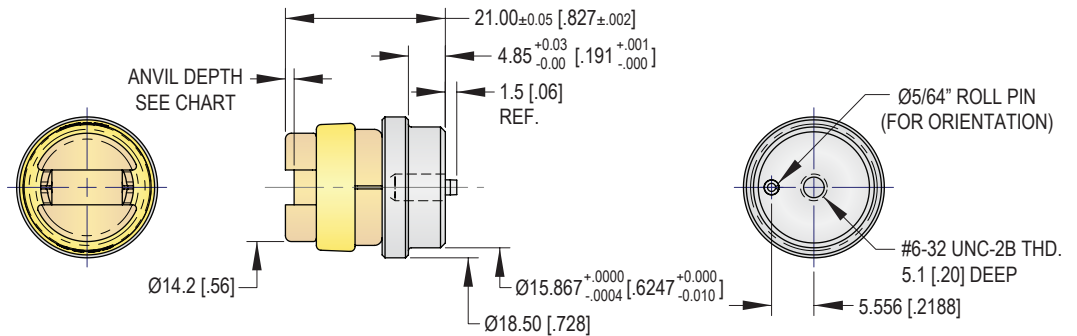

3.0 Elastomer Style “A” Die Holder

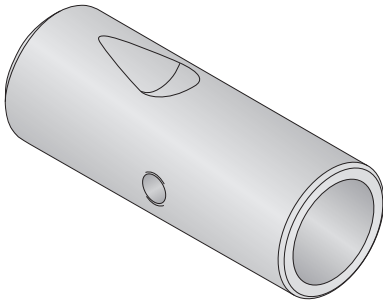
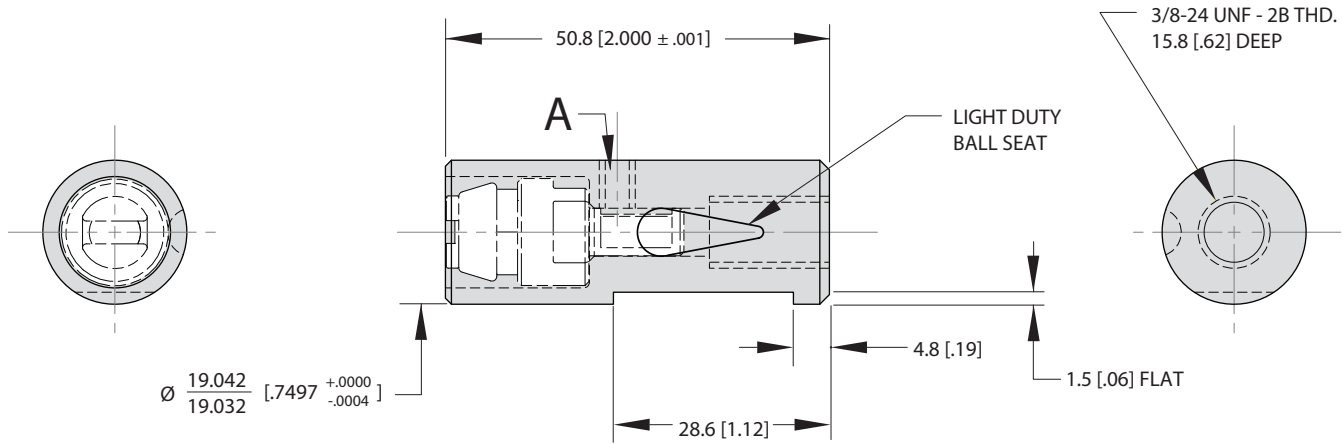

Mounting Type	A	Order No.
Imperial	#10-32 UNF -2B THD.	007689

4.6 Elastomer Style "A" Die Holder

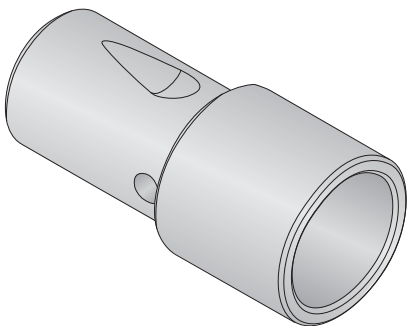
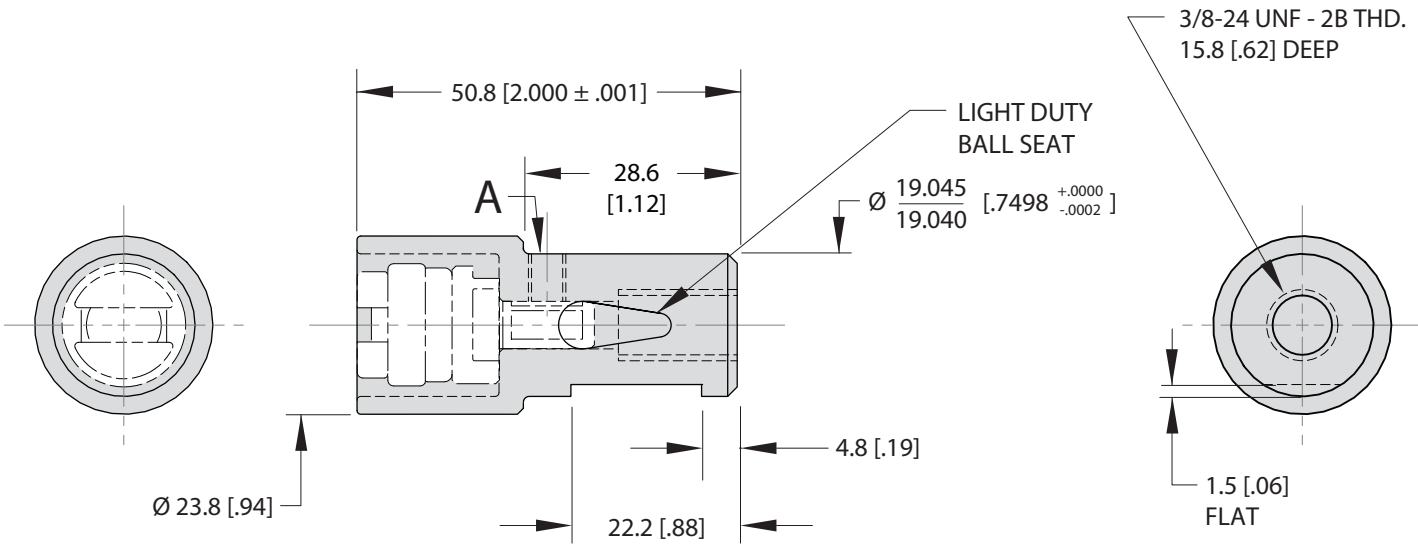

Mounting Type	A	Order No.
Imperial	M5x0.8 -6H THD.	013888

Lance-N-Loc™ Die Mounting Information

3.0 Elastomer Style "A" Die Pocket Information

3.8

4.6

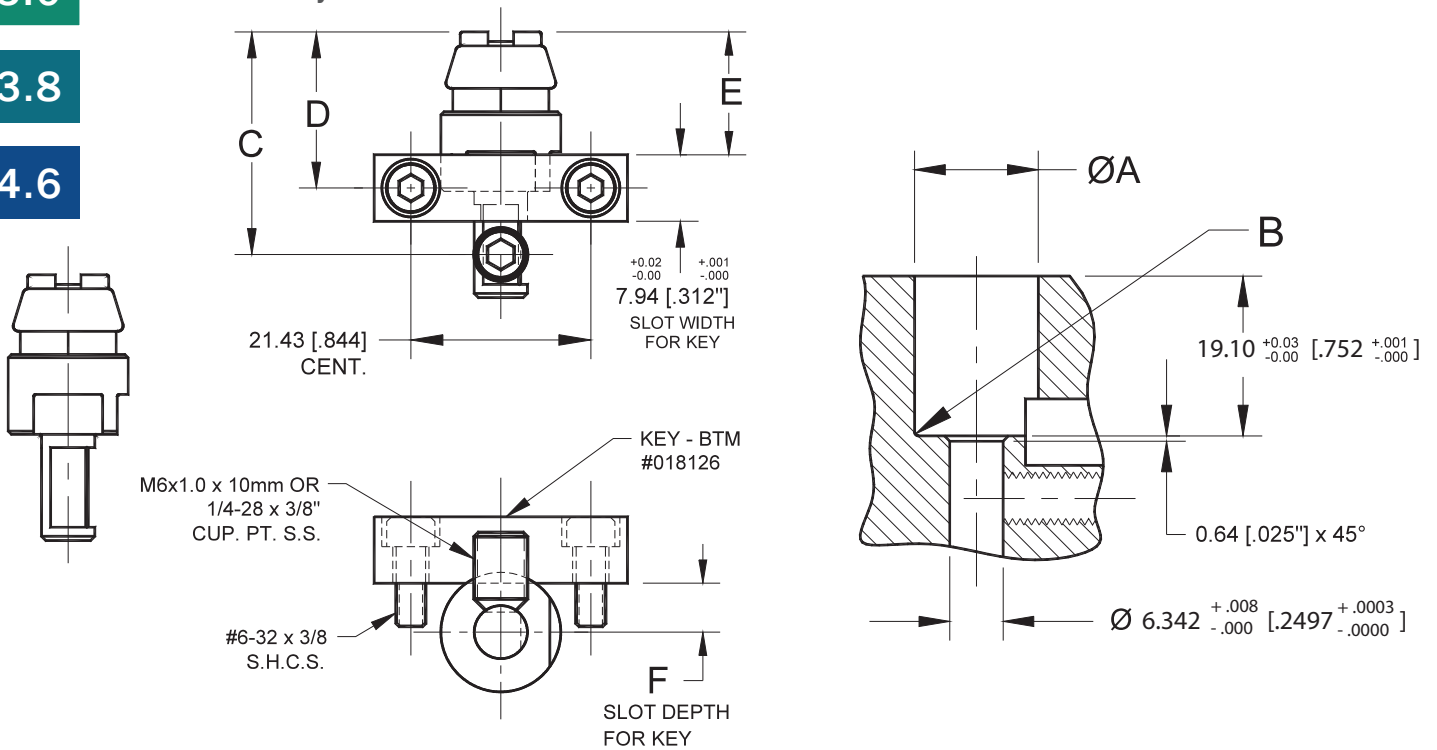

Tooling Size	A	B	C	D	E	F
3.0	14.73 [.580]	R0.51 [.020]	26.59 [1.047]	18.64 [.734]	14.68 [.578]	5.84 ± 0.02 [.230 ± .001]
3.8	15.88 [.625]	R0.64 [.025]	26.59 [1.047]	18.64 [.734]	14.68 [.578]	5.84 ± 0.02 [.230 ± .001]
4.6	19.05 [.750]	R0.64 [.025]	27.79 [1.094]	19.84 [.781]	15.88 [.625]	6.22 ± 0.02 [.245 ± .001]

3.0 Elastomer Short Insert Die Pocket Information

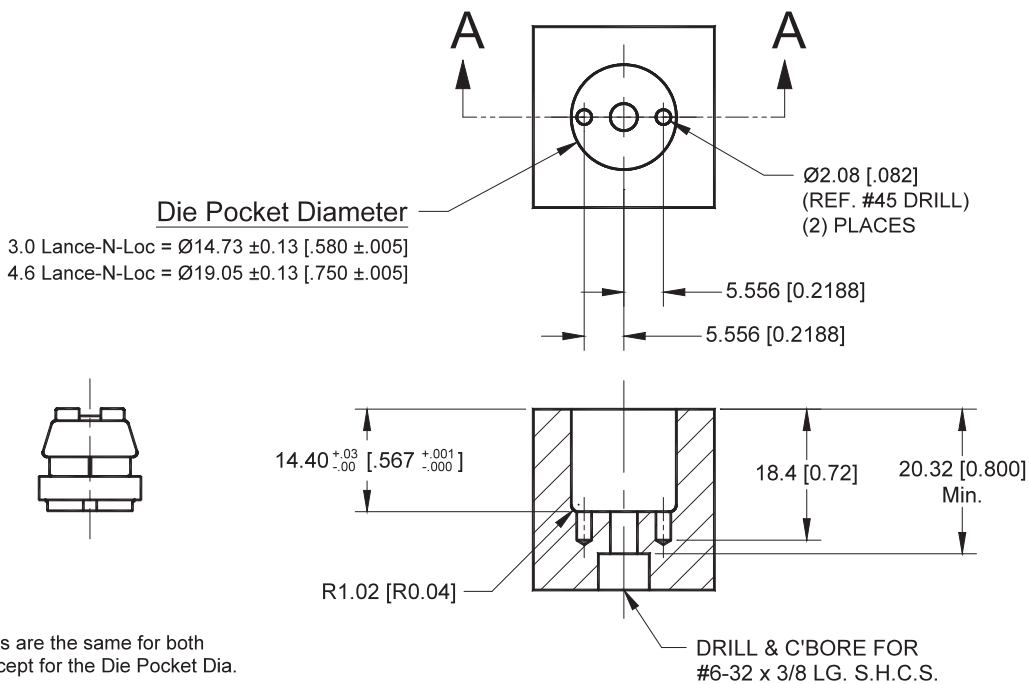

Note:
All dimensions are the same for both joint sizes except for the Die Pocket Dia.

4.6

Elastomer Short Insert Die Pocket Information

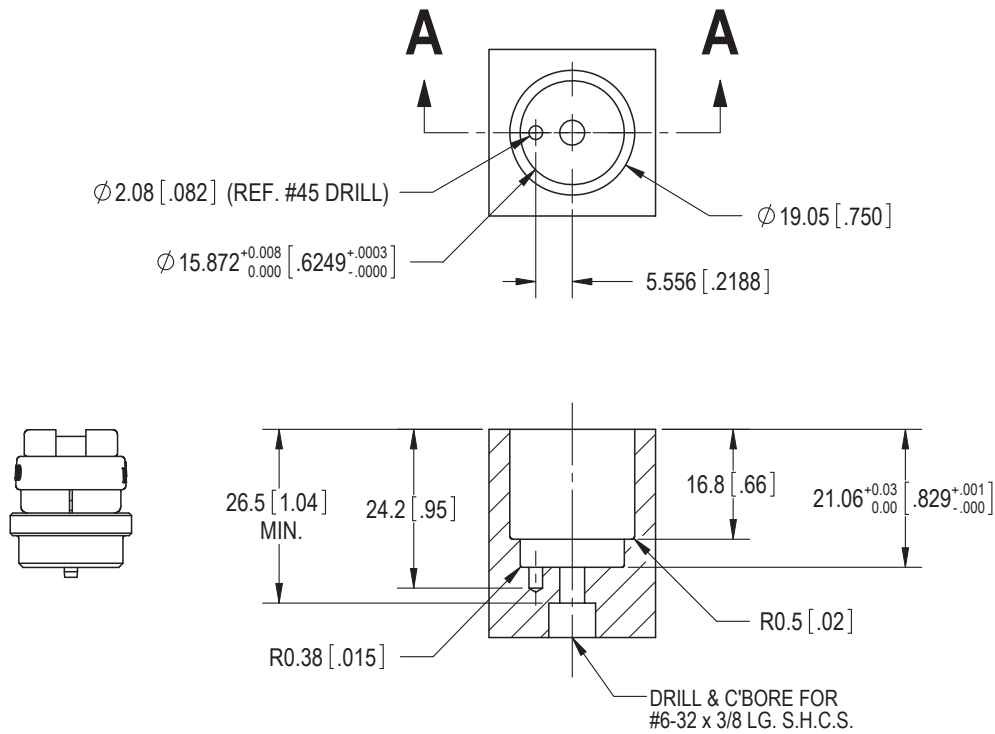

Two Blade Die Pocket Information

2 bladed dies require a clearance pocket for the blades to open freely.

The locational tolerance to the centerline of the die should be ± 0.013 [.0005"].

A hardened die block is required; preferably a minimum of 4150HT steel.

Two Bladed Combo Block Die Pocket Information

For **3.0**, & **4.6** Lance-N-Loc™ joints.

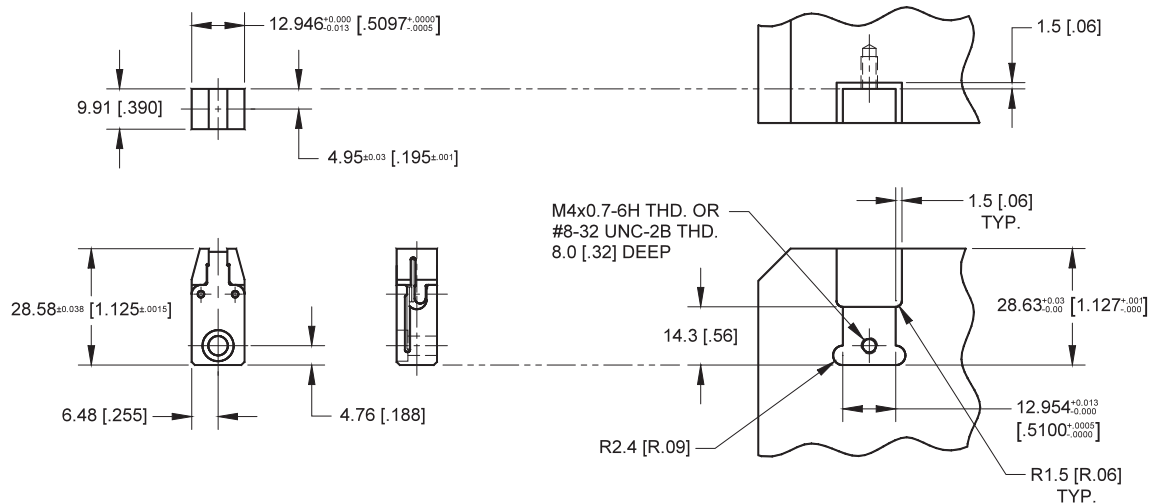

BTM[®] CORPORATION

BTM has a wide range of standard products to meet your needs including:

PNEUMATIC CLAMPS & GRIPPERS

Light & Heavy Duty Clamps

Clamps range from light duty omni-directional head clamps to heavy duty precision sealed power clamps.



Light & Heavy Duty Grippers

BTM's Gripper line ranges from compact light duty models to locking & non-locking heavy duty models.



SHEET METAL JOINING

Tog-L-Loc[®]

BTM's Tog-L-Loc[®] sheet metal joining system is a cold forming process that quickly joins pre-painted, galvanized, coated, and dissimilar metals.

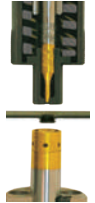

Lance-N-Loc[™]

BTM's Lance-N-Loc[™] Joining System produces clean, strong and consistent joints in most coated or uncoated metals.



PIN PRODUCTS

Precision Shot Pin cylinders

BTM's Precision Part Locators are used whenever your production needs require locating precise holes in a workpiece.



Pin Locator Clamps

BTM's Pin Locator Clamps and Single Finger clamps are used in stationary part nests, welding fixtures, transfer systems, robot end effectors and numerous other clamping applications. These clamps locate and hold the work while other operations are performed.



Standard pin sizes range from 12.5mm - 40mm.

Ways to Tog-L-Loc[®]



Press Brakes



Handheld Units



Die Sets



Universal Presses



Hydraulic Units



Specialized Units

For more information, or to see our full line of products, please visit:

www.BTMcorp.com