

Tog-Loc[®] Clinch Tooling : 940 Series

Standard Dies, Punches, Strippers, & Holders for Clinching Sheet Metal

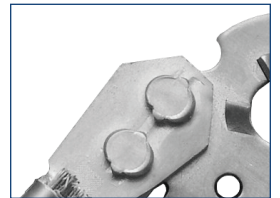
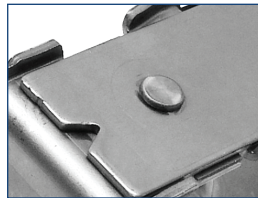

Features 3.0, 3.8, 4.6, 5.5, 6.4, and 7.6mm Tooling

Contains standard 940 Punches, Dies & Holders

“Mini” and Standard Die Styles Included



BTM[®]
EUROPE

www.btm-europe.de

Fastening without Fasteners

BTM's patented Tog-L-Loc® sheet metal joining system is the simple solution for fastening plain or coated sheet metals. Tog-L-Loc® forms a strong, leakproof "button" headed joint without welding or riveting in almost any combination of ductile sheet metals. The Tog-L-Loc® system is widely used in the manufacture of automobiles, appliances, furniture, electrical products, building supplies, and more.

For information on how to apply this tooling, or to inquire about other types of Tog-L-Loc® tooling, contact BTM Corporation.

940 Punch Retention: Compared to a set screw, the 940 retention method is more robust during normal machine cycling.

940 Die Advantages: 940 dies feature a built in die shield with integrated drain holes which helps keep the die clean in applications using lubricated materials.

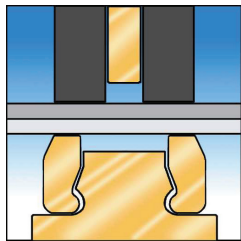

CLAMPS

The first step in the Tog-L-Loc® process involves clamping of the material with a punch side stripper.

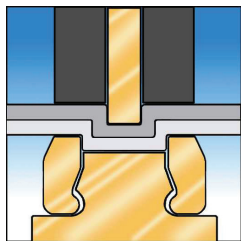

DRAWS

Next, the punch draws the material into the die.

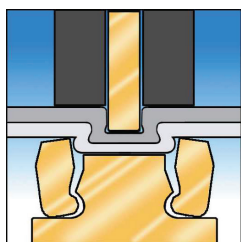

LOCKS

As the material flows into the die, the die blades expand, allowing the metal to flow into a strong interlock.

A few examples of parts clinched using Tog-L-Loc®



Aluminized Steel Exhaust Shield



Laminated Sound Deadening Material

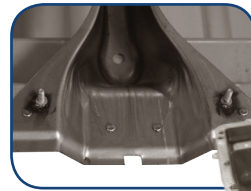

Galvanized Duct

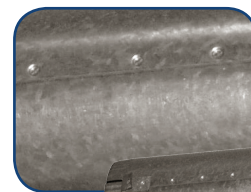

Pre-Painted Steel Refrigerator Cabinet



Tog-L-Loc® Die Comparison

Dies In this Catalog	Other Tog-L-Loc® Dies	
 <p>940 Series Dies</p> <p>940 Dies feature a built in die shield that surrounds an elastomer ring (or a canted coil spring) and three die blades.</p>	 <p>Three Bladed Elastomer Dies</p> <p>These dies are ideal when the die guarding can be modified to incorporate contour features in a part.</p>	 <p>Two Bladed Dies</p> <p>Ideal for very tight joining locations up against a flange, where the blades can operate parallel.</p>

Before you Order

Follow these steps to ensure your satisfaction with Tog-L-Loc®:

1. Submit a sample of your part and or material to the BTM sample department.
A “Sample Data Sheet” will be used to record what tooling was used to make your sample, as well as the resulting shear and peel strengths.
2. Test your sample
3. Upon your approval, contact the BTM application engineering department and we will help you select the correct punch, die, stripper, and holders.
This catalog will be used as a reference.
4. Order the required Tog-L-Loc® or Lance-N-Loc® tooling for your application.

Using the Die Charts in this Catalog

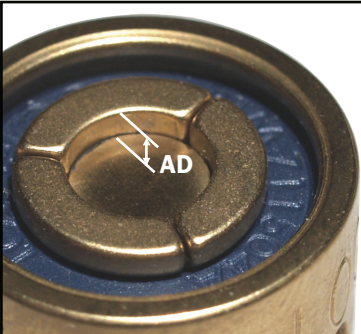

Anvil Depth

The Anvil Depth is the distance from the anvil to the top of the die blades. The correct anvil depth for an application is determined through testing and/or surrogate joint data at BTM, not by material thickness.

Standard Die
[Contact BTM for compatibility.]

Dies intended for use with Aluminum.

AD	Standard	Aluminum
.020	71150005	76010005

Contact BTM Europe to ensure that you order the correct tooling configuration for the material that you are joining.

Safety Note

It is the customer and/or user’s responsibility to provide proper safety controls and/or guarding when a pinch point is present.

TOG-L-LOC® TOOLING TERMINOLOGY

940 SERIES PUNCH HOLDERS

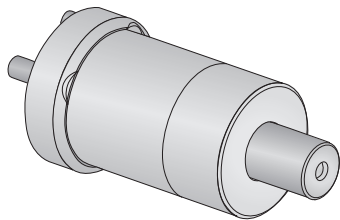

Round Punch Holder
[For Die Set Mounting]

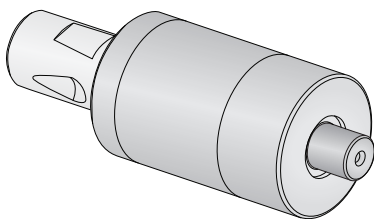

Shank Punch Holder

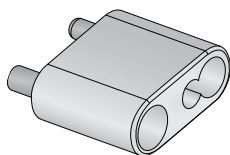

Thin Punch Holder

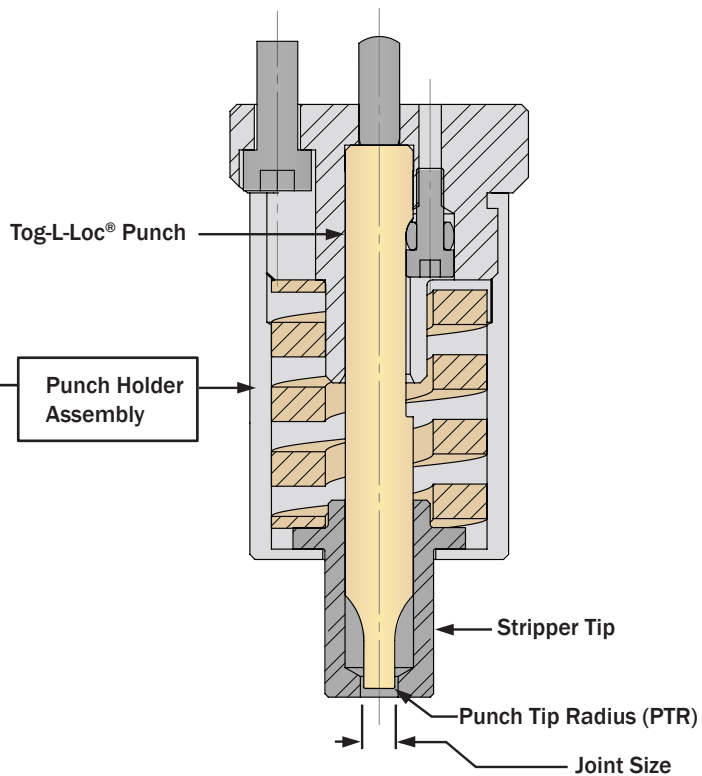

940 SERIES DIE HOLDERS

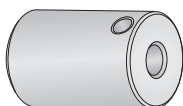

Style "A" Die Holder
[For Style "A" Dies]

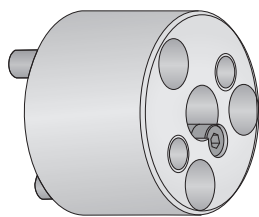

Round Die Holder

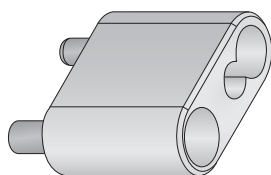

Thin Die Holder

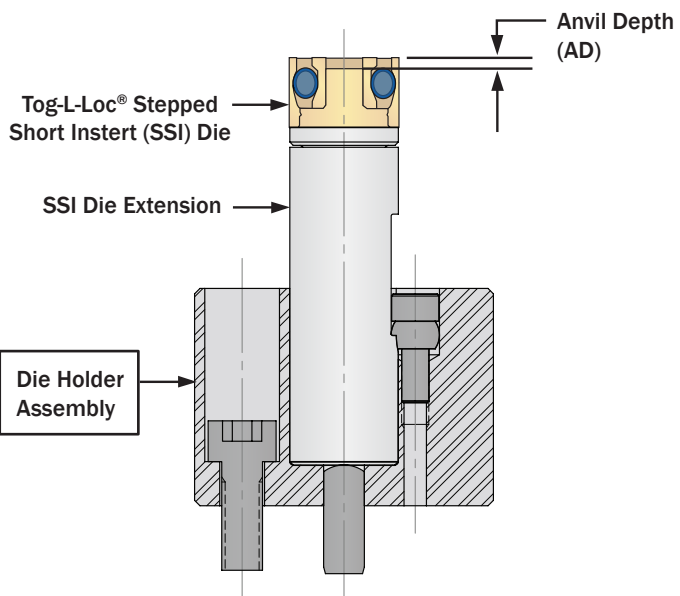
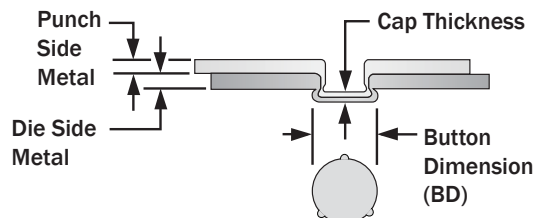

TABLE OF CONTENTS

940 SERIES PUNCHES

3.0	6
3.8	6
4.6	6
5.5	7
6.4	7
7.6	7

940 SERIES PUNCH ASSEMBLIES AND HOLDERS

Round Punch Holder	8
THIN Punch Holder	9
SS10 Metric Shank Punch Holder	10
SS20 Metric Shank Punch Holder	11

940 SERIES TOG-L-LOC® DIES

MINI 3.0	12
3.0	13
MINI 3.8	14
3.8	15
MINI 4.6	16
4.6	17
MINI 5.5	18
5.5	19
MINI 6.4	20
6.4	21
MINI 7.6	22
7.6	23

940 SERIES DIE HOLDERS

Style "A" Die Holder	24
Round Die Holder	24
THIN Die Holder	25

USING 940 DIES

Mounting Information	26-27
----------------------------	-------

3.0 940 Series Punch

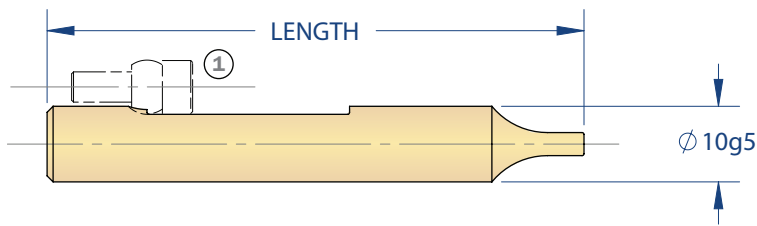

Not Included

- ① One (1) Punch Retaining Screw Ass'y [BTM No. 018217]

	Length		Punch Tip Radius	
	mm	.010	.020	
Preferred	71	713800A	713800E	
	80	713800B	713800F	
	90	713800C	713800G	
	100	713800D	713800H	

Compatible Holder Styles

Die Set Mounting Round Holder	p.8
THIN Holder	p.9
Shank Mounting [SS10]	p.10
[SS20]	p.11

3.8 940 Series Punch

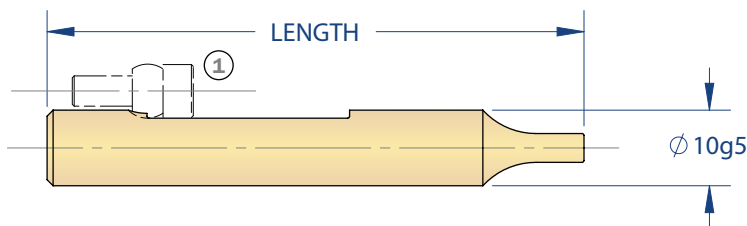

Not Included

- ① One (1) Punch Retaining Screw Ass'y [BTM No. 018217]

	Length		Punch Tip Radius	
	mm	.010	.020	
Preferred	71	793600A	793600B	
	80	793600C	793600D	
	90	793600E	793600F	
	100	793600G	793600H	

Compatible Holder Styles

Die Set Mounting Round Holder	p.8
THIN Holder	p.9
Shank Mounting [SS20]	p.11

4.6 940 Series Punch

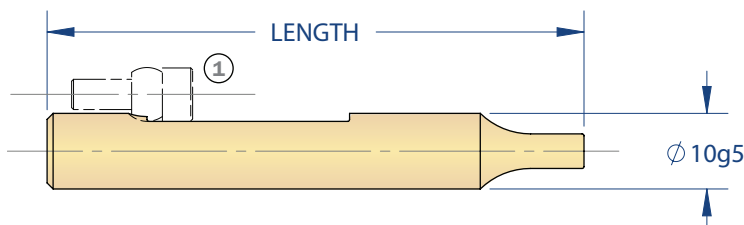

Not Included

- ① One (1) Punch Retaining Screw Ass'y [BTM No. 018217]

	Length		Punch Tip Radius	
	mm	.010	.020	
Preferred	71	713900A	713900E	
	80	713900B	713900F	
	90	713900C	713900G	
	100	713900D	713900H	

Compatible Holder Styles

Die Set Mounting Round Holder	p.8
THIN Holder	p.9
Shank Mounting [SS10]	p.10
Shank Mounting [SS20]	p.11

5.5 940 Series Punch

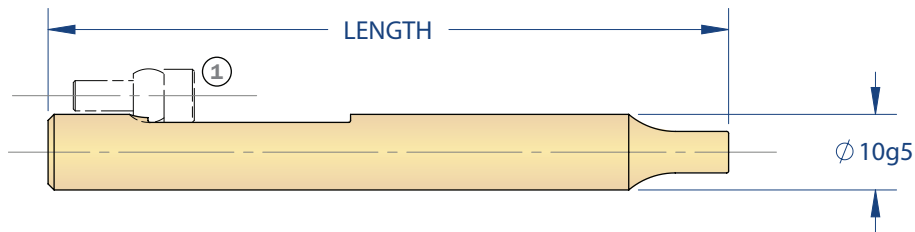

Not Included

- ① One (1) Punch Retaining Screw Ass'y [BTM No. 018217]

Length	Punch Tip Radius	
	mm	.010
71	739000A	739000B
80	739000C	739000D
90	739000E	739000F
100	739000G	739000H

Preferred

Compatible Holder Styles

Die Set Mounting Round Holder	p.8
THIN Holder	p.9
Shank Mounting [SS20]	p.11

6.4 940 Series Punch

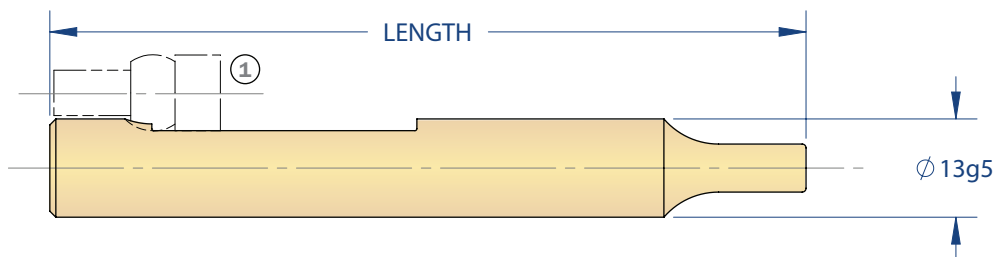

Not Included

- ① One (1) Punch Retaining Screw Ass'y [BTM No. 023228]

Length	Punch Tip Radius	
	mm	.010
100	PD201200A	PD201200C
125	PD201200B	PD201200D

Compatible Holder Styles

Die Set Mounting Round Holder	p.8
THIN Holder	p.9

7.6 940 Series Punch

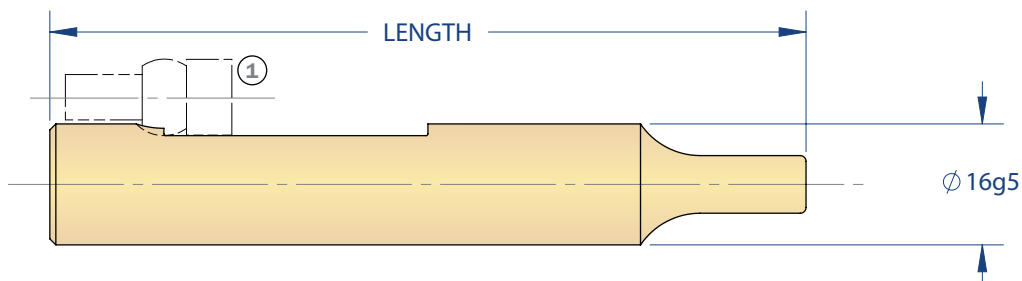

Not Included

- ① One (1) Punch Retaining Screw Ass'y [BTM No. 023228]

Length	Punch Tip Radius	
	mm	.020
100	780100A	780100C
125	780100B	780100D

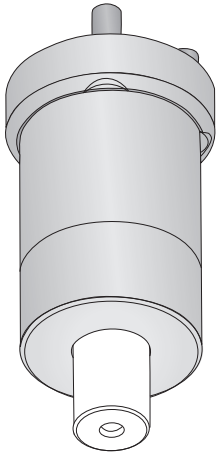

ASSEMBLY INCLUDES:

- ① One (1) Punch Holder
- ② One (1) Stripper Spring
- ③ One (1) Stripper Can
- ④ One (1) Punch Retaining Screw Ass'y
- ⑤ One (1) Dowel Pin
- ⑥ Three (3) Mounting Screws

NOT INCLUDED [EXCEPT 5.5 & 6.4 ASSEMBLIES]

- ⑦ One (1) Tog-L-Loc® Punch (see p. 6-7)
- ⑧ One (1) Stripper tip (see chart)

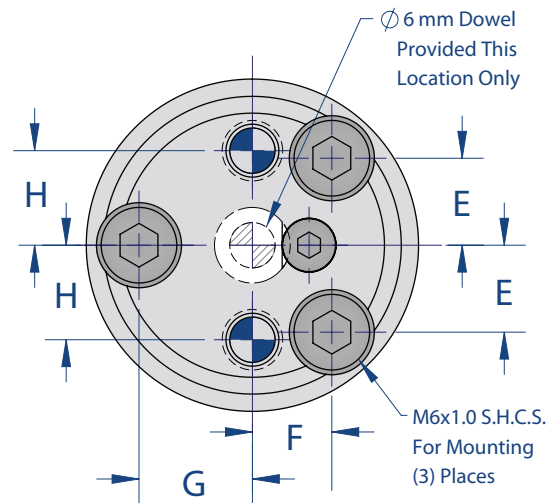
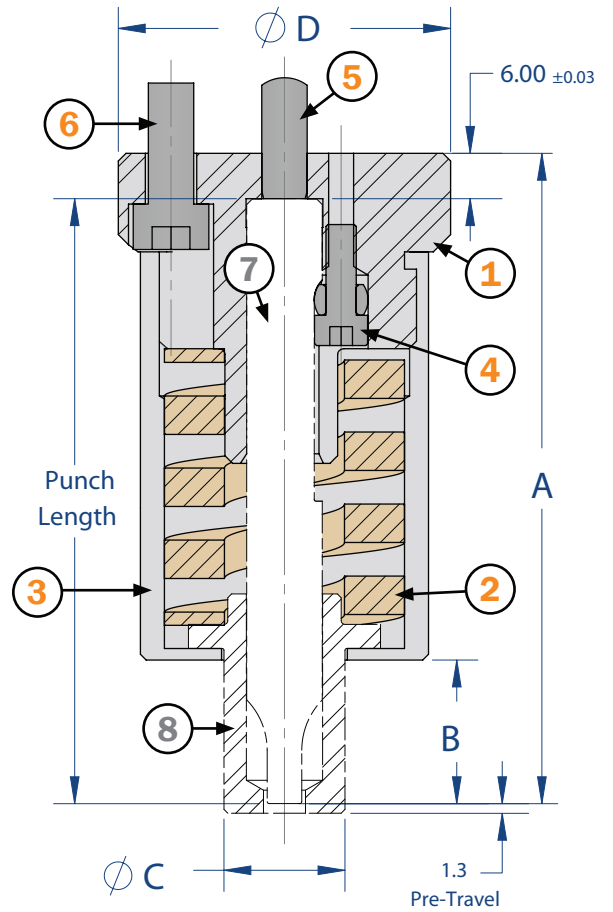

Tooling	Punch Length	A	B	C	D	E	F	G	H
3.0	71	77.0	10.0	Ø12.0	Ø44	11.5	10.5	15.0	12.5
	80	86.0	19.0						
	90	96.0	29.0						
	100	106.0	39.0						
3.8	71	77.0	10.0	Ø14.0	Ø44	11.5	10.5	15.0	12.5
	80	86.0	19.0						
	90	96.0	29.0						
	100	106.0	39.0						
4.6	71	77.0	10.0	Ø16.0	Ø44	11.5	10.5	15.0	12.5
	80	86.0	19.0						
	90	96.0	29.0						
	100	106.0	39.0						
5.5	90	96.0	17.0	Ø16.0	Ø44	11.5	10.5	15.0	12.5
	100	106.0	27.0						
6.4	100	106.0	12.0	Ø22.0	Ø57	13.0	19.5	19.5	19.5
	125	131.0	37.0						

Punch Length [Punch Sold Separately (except 5.5 & 6.4) See p. 6-7 for punch info.]

Tooling Size	71mm	80mm	90mm	100mm	125mm
3.0	Stripper Tip*	713402A	713403A	713404A	713405A
	SS20 Ass'y	713400A			N/A
3.8	Stripper Tip*	793901A	793901C	793901E	793901G
	SS20 Ass'y	794500A			N/A
4.6	Stripper Tip*	713406A	713407A	713408A	713409A
	SS20 Ass'y	713400A			N/A
5.5	SS25 Ass'y	N/A	N/A	.010 PTR	.020 PTR
				PD241800A	PD241800B
6.4	SS30 Ass'y	N/A	N/A	.010 PTR	.020 PTR
				PD214400A	PD214400C

* A Stripper Tip must be specified when ordering a Round Punch Holder for all tooling sizes except 5.5 & 6.4. | PTR = Punch Tip Radius

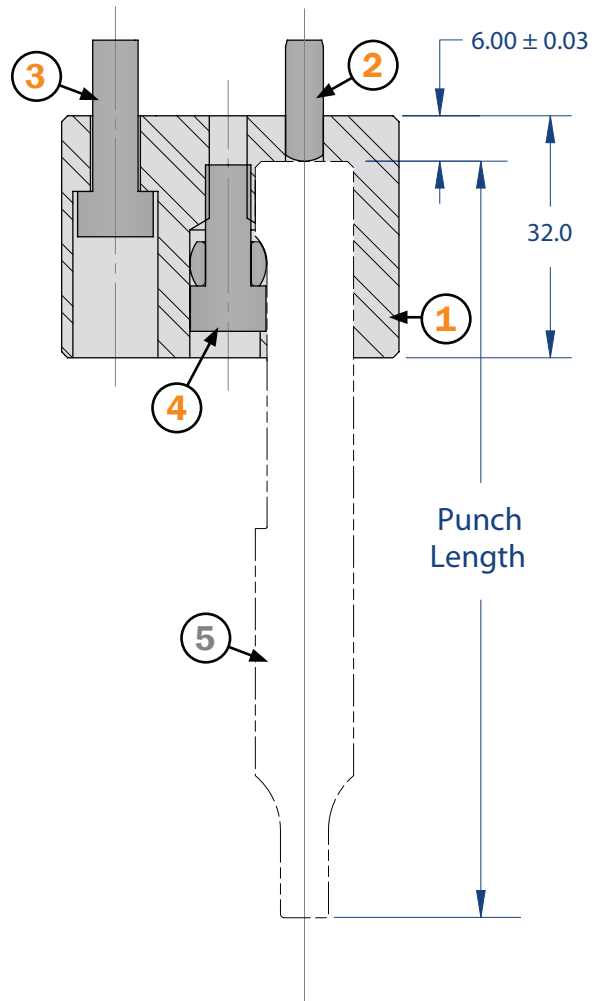
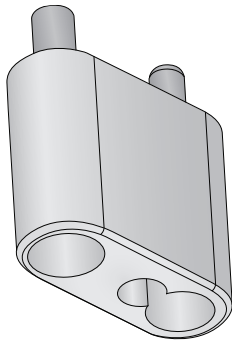

ASSEMBLY INCLUDES:

- ① One (1) Punch Holder
- ② One (1) Dowel Pin
- ③ One (1) Mounting Screw
- ④ One (1) Punch Retaining Screw Assembly

NOT INCLUDED

- ⑤ One (1) Tog-L-Loc® Punch (see p. 6-7)
- One (1) Stripper (Not Shown - Contact BTM)

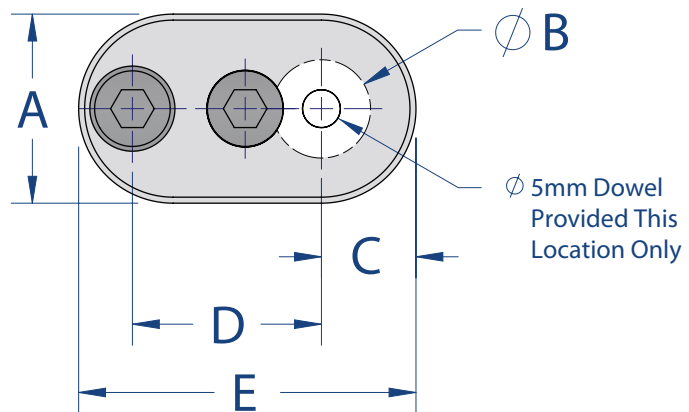

Tooling Size	A	B	C	D	E	BTM Order No.
3.0	15.0	Ø10H6	7.5	22.50	37.0	737400B
3.8	15.0	Ø10H6	7.5	22.50	37.0	737400D
4.6	15.0	Ø10H6	7.5	22.50	37.0	737400D
5.5	15.0	Ø10H6	7.5	22.50	37.0	737400D
6.4	25.0	Ø13H6	12.5	25.00	44.5	PD214600E

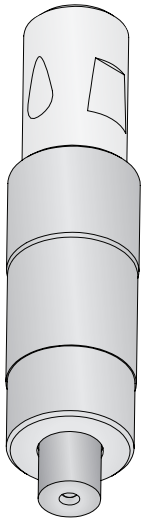

ASSEMBLY INCLUDES:

- ① One (1) Punch Holder
- ② One (1) Stripper Spring
- ③ One (1) Stripper Can
- ④ One (1) Punch Retaining Screw Assembly
- ⑤ One (1) 940 Tog-L-Loc® Punch
- ⑥ One (1) Stripper Tip

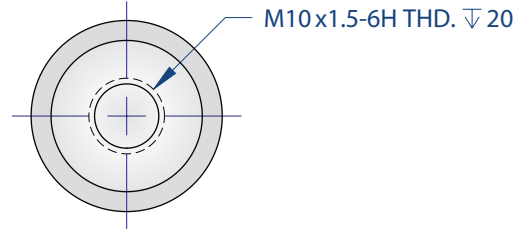

3.0 Tooling

Punch	PTR	A	B	C	BTM No.
71	.010	108	Ø10.0	Ø12.0	787700J
	.020	108	Ø10.0	Ø12.0	787700K
80	.010	117	Ø19.0	Ø12.0	787700L
	.020	117	Ø19.0	Ø12.0	787700M
90	.010	127	Ø29.0	Ø12.0	787700N
	.020	127	Ø29.0	Ø12.0	787700P
100	.010	137	Ø39.0	Ø12.0	787700R
	.020	137	Ø39.0	Ø12.0	787700S

PTR = Punch Tip Radius

3.8 Tooling

Punch	PTR	A	B	C	BTM Order No.
71	.010	108	Ø10.0	Ø16.5	PD237700A
	.020	108	Ø10.0	Ø16.5	PD237700B
80	.010	117	Ø19.0	Ø16.5	PD237700C
	.020	117	Ø19.0	Ø16.5	PD237700D
90	.010	127	Ø29.0	Ø16.5	PD237700E
	.020	127	Ø29.0	Ø16.5	PD237700F
100	.010	137	Ø39.0	Ø16.5	PD237700G
	.020	137	Ø39.0	Ø16.5	PD237700H

PTR = Punch Tip Radius

4.6 Tooling

Punch	PTR	A	B	C	BTM No.
71	.010	108	Ø10.0	Ø16.5	787700A
	.020	108	Ø10.0	Ø16.5	787700B
80	.010	117	Ø19.0	Ø16.5	787700C
	.020	117	Ø19.0	Ø16.5	787700D
90	.010	127	Ø29.0	Ø16.5	787700E
	.020	127	Ø29.0	Ø16.5	787700F
100	.010	137	Ø39.0	Ø16.5	787700G
	.020	137	Ø39.0	Ø16.5	787700H

PTR = Punch Tip Radius

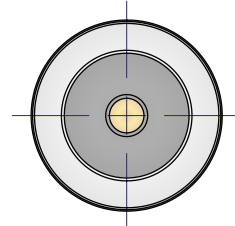
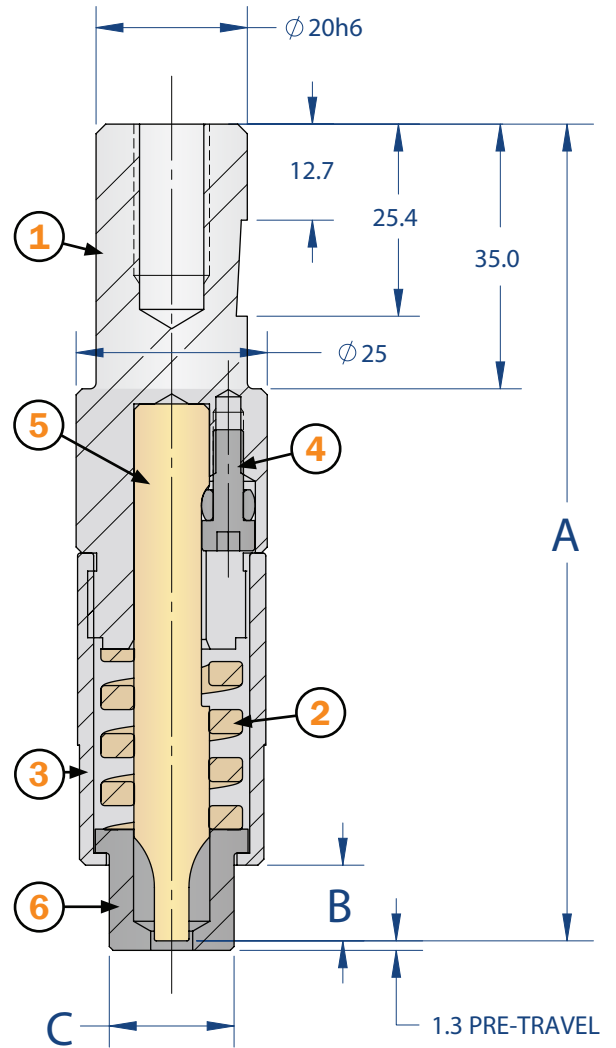

3.0 Tooling

Punch	PTR	A	B	C	BTM No.
71	.010	108	Ø10.0	Ø12.0	022516
	.020	108	Ø10.0	Ø12.0	022517
80	.010	117	Ø19.0	Ø12.0	022518
	.020	117	Ø19.0	Ø12.0	022519
90	.010	127	Ø29.0	Ø12.0	022520
	.020	127	Ø29.0	Ø12.0	022521
100	.010	137	Ø39.0	Ø12.0	022522
	.020	137	Ø39.0	Ø12.0	022523

PTR = Punch Tip Radius

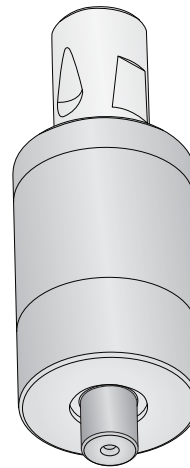

ASSEMBLY INCLUDES:

- ① One (1) Punch Holder
- ② One (1) Stripper Spring
- ③ One (1) Stripper Can
- ④ One (1) Punch Retaining Screw Ass'y
- ⑤ One (1) Tog-L-Loc® Punch
- ⑥ One (1) Stripper Tip

3.8 Tooling

Punch	PTR	A	B	C	BTM No.
71	.010	108	Ø10.0	Ø14.0	793900K
	.020	108	Ø10.0	Ø14.0	793900L
80	.010	117	Ø19.0	Ø14.0	793900M
	.020	117	Ø19.0	Ø14.0	793900N
90	.010	127	Ø29.0	Ø14.0	793900P
	.020	127	Ø29.0	Ø14.0	793900R
100	.010	137	Ø39.0	Ø14.0	793900S
	.020	137	Ø39.0	Ø14.0	793900T

PTR = Punch Tip Radius

4.6 Tooling

Punch	PTR	A	B	C	BTM No.
71	.010	108	Ø10.0	Ø16.0	018925
	.020	108	Ø10.0	Ø16.0	018926
80	.010	117	Ø19.0	Ø16.0	018927
	.020	117	Ø19.0	Ø16.0	018928
90	.010	127	Ø29.0	Ø16.0	018929
	.020	127	Ø29.0	Ø16.0	018930
100	.010	137	Ø39.0	Ø16.0	018931
	.020	137	Ø39.0	Ø16.0	018932

PTR = Punch Tip Radius

5.5 Tooling

Punch	PTR	A	B	C	BTM No.
71	.010	108	Ø10.0	Ø19.0	PD244200A
	.020	108	Ø10.0	Ø19.0	PD244200B
80	.010	117	Ø19.0	Ø19.0	PD244200C
	.020	117	Ø19.0	Ø19.0	PD244200D
90	.010	127	Ø29.0	Ø19.0	PD244200E
	.020	127	Ø29.0	Ø19.0	PD244200F
100	.010	137	Ø39.0	Ø19.0	PD244200G
	.020	137	Ø39.0	Ø19.0	PD244200H

PTR = Punch Tip Radius

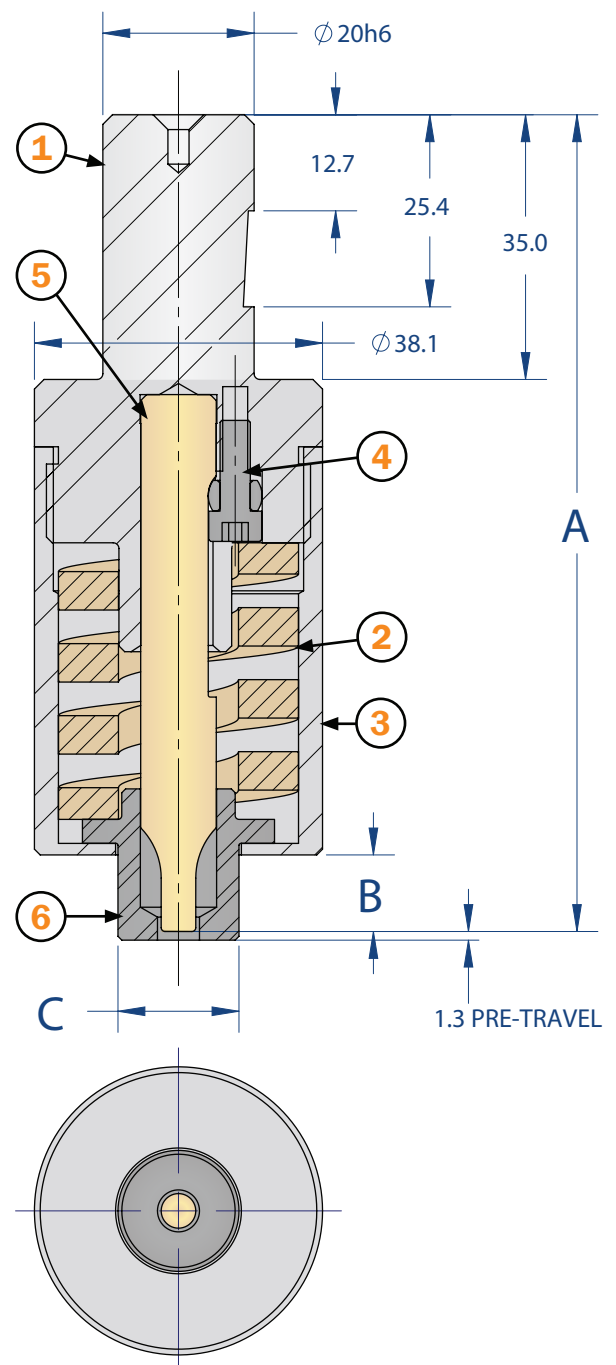

3.0 Tog-L-Loc® 940 Series “MINI” DIES

“Mini” dies are used when joining minimum flange widths and total material thickness permits joining with the maximum allowable button dimension (BD). Maximum BD for each mini die is stated.

“Mini” Style “A” die

AD	Standard
.020	710200BE
.025	710200CE
.030	710200DE
.035	710200EE
.040	710200FE

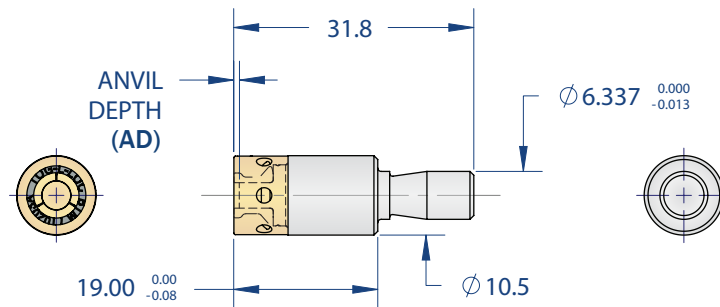

Contact BTM for maximum total material thickness this die can join.
Maximum Button Diameter (BD) for this die is Ø4.95

“Mini” Stepped Short Insert (SSI) die

AD	Standard
.020	751800BE
.025	751800CE
.030	751800DE
.035	751800EE
.040	751800FE

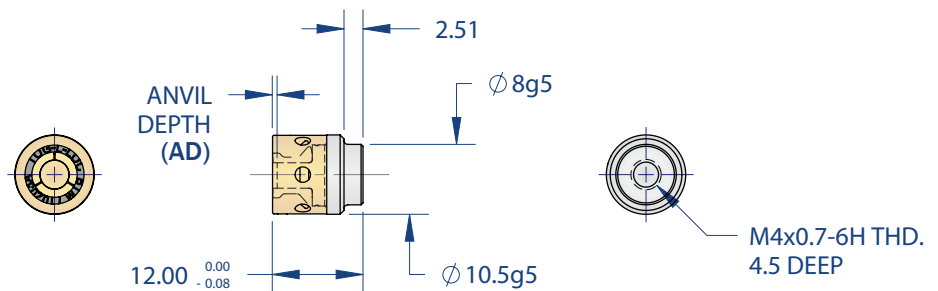

Contact BTM for maximum total material thickness this die can join.
Maximum Button Diameter (BD) for this die is Ø4.95

“Mini” SSI Die Extensions

Length	Extension
40mm	PD220200A
60mm	PD220200B
80mm	PD220200C
100mm	PD220200D

ASSEMBLY INCLUDES:

- ① One (1) Extension
- ② One (1) Die Retaining Screw

NOT INCLUDED:

- ③ One (1) 3.0 “MINI” SSI Tog-L-Loc® Die
- ④ One (1) 940 Retaining Screw (BTM No. 018217)

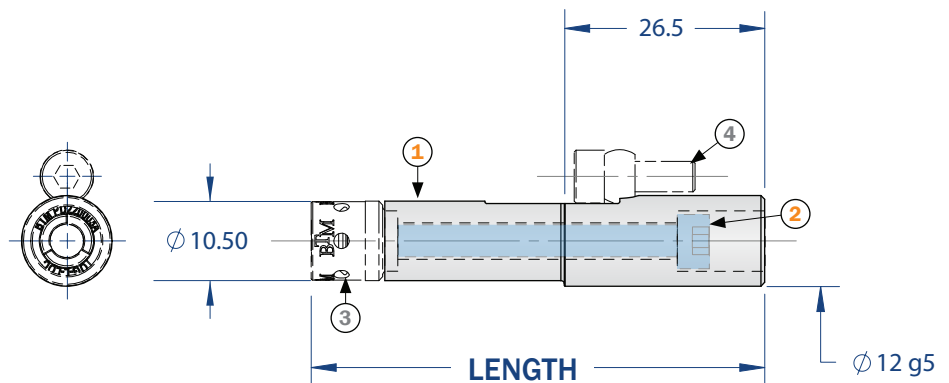

Style "A" die

AD	Standard
.020	718200BE
.025	718200CE
.030	718200DE
.035	718200EE
.040	718200FE
.045	718200GE
.050	718200HE

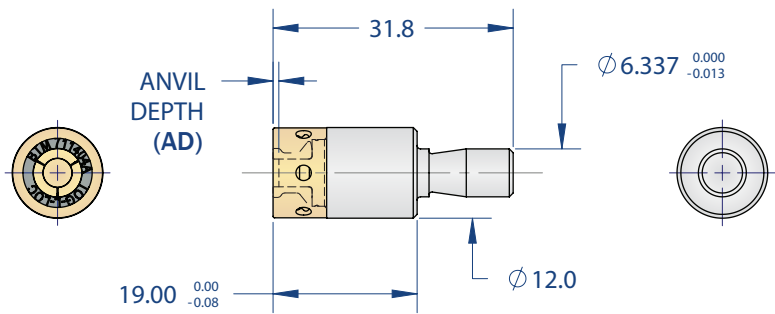

Stepped Short Insert (SSI) die

AD	Standard
.020	751000BE
.025	751000CE
.030	751000DE
.035	751000EE
.040	751000FE
.045	751000GE
.050	751000HE

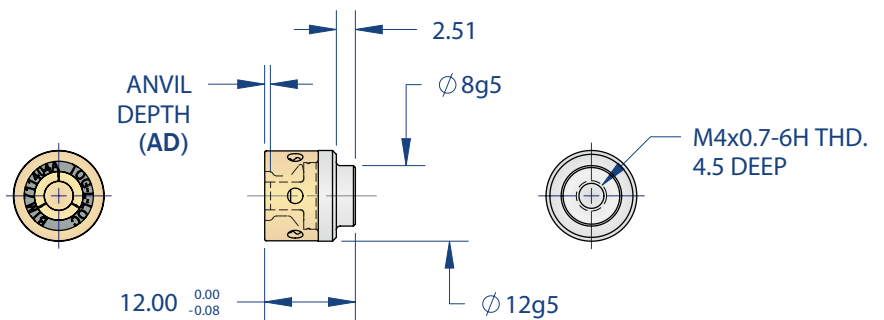

SSI Die Extensions

Length	Extension
40mm	PD220300A
60mm	PD220300B
80mm	PD220300C
100mm	PD220300D

ASSEMBLY INCLUDES:

- ① One (1) Extension
- ② One (1) Die Retaining Screw

NOT INCLUDED:

- ③ One (1) 3.0 SSI Tog-L-Loc® Die
- ④ One (1) 940 Retaining Screw (BTM No. 018217)

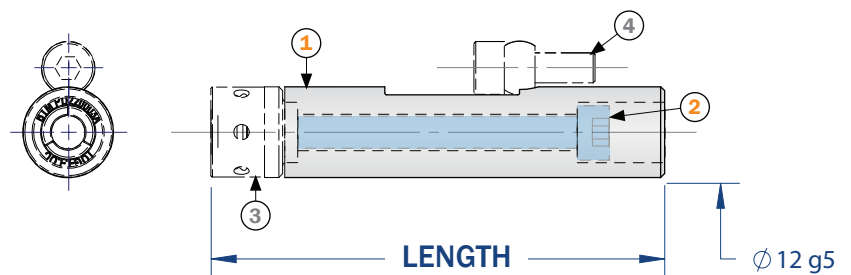

3.8 Tog-L-Loc® 940 Series “MINI” DIES

“Mini” dies are used when joining minimum flange widths and total material thickness permits joining with the maximum allowable button dimension (BD). Maximum BD for each mini die is stated.

“Mini” Style “A” die

AD	Standard
.020	PD220800BE
.025	PD220800CE
.030	PD220800DE
.035	PD220800EE
.040	PD220800FE
.045	PD220800GE
.050	PD220800HE

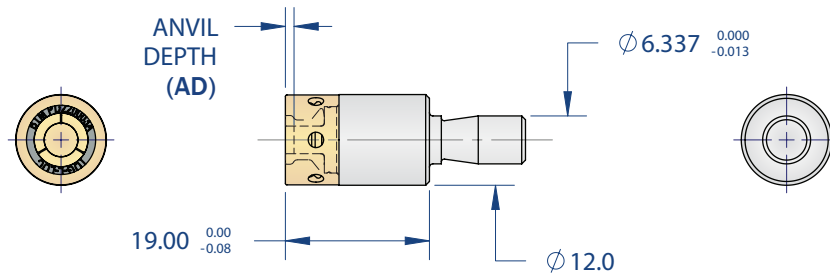

Contact BTM for maximum total material thickness this die can join.
Maximum Button Diameter (BD) for this die is Ø6.1

“Mini” Stepped Short Insert (SSI) die

AD	Standard
.020	PD220000BE
.025	PD220000CE
.030	PD220000DE
.035	PD220000EE
.040	PD220000FE
.045	PD220000GE
.050	PD220000HE

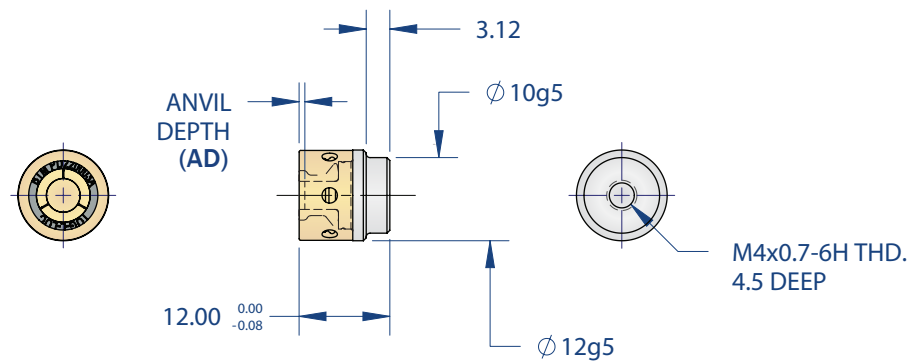

Contact BTM for maximum total material thickness this die can join.
Maximum Button Diameter (BD) for this die is Ø6.1

“Mini” SSI Die Extensions

Length	Extension
40mm	PD220400A
60mm	PD220400B
80mm	PD220400C
100mm	PD220400D

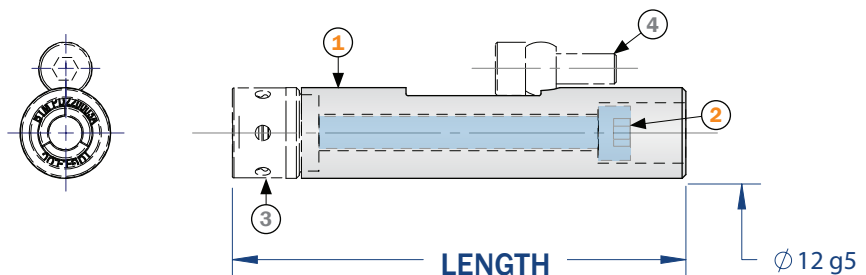

ASSEMBLY INCLUDES:

- ① One (1) Extension
- ② One (1) Die Retaining Screw

NOT INCLUDED:

- ③ One (1) 3.8 “MINI” SSI Tog-L-Loc® Die
- ④ One (1) 940 Retaining Screw (BTM No. 018217)

Style "A" die

AD	Standard	Aluminum
.020	794600BE	PD214300BE
.025	794600CE	PD214300CE
.030	794600DE	PD214300DE
.035	794600EE	PD214300EE
.040	794600FE	PD214300FE
.045	794600GE	PD214300GE
.050	794600HE	PD214300HE
.055	794600JE	PD214300JE

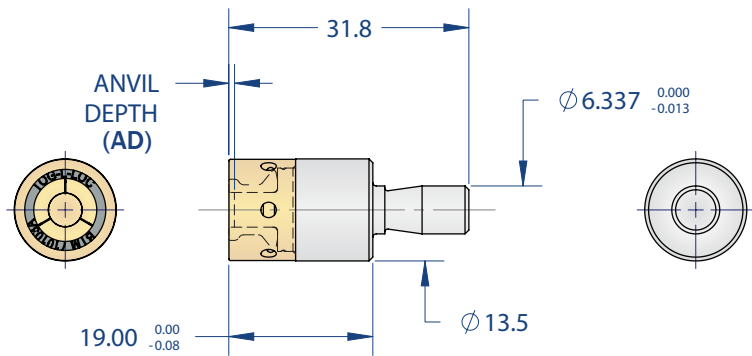

Stepped Short Insert (SSI) die

AD	Standard
.020	793700BE
.025	793700CE
.030	793700DE
.035	793700EE
.040	793700FE
.045	793700GE
.050	793700HE
.055	793700JE

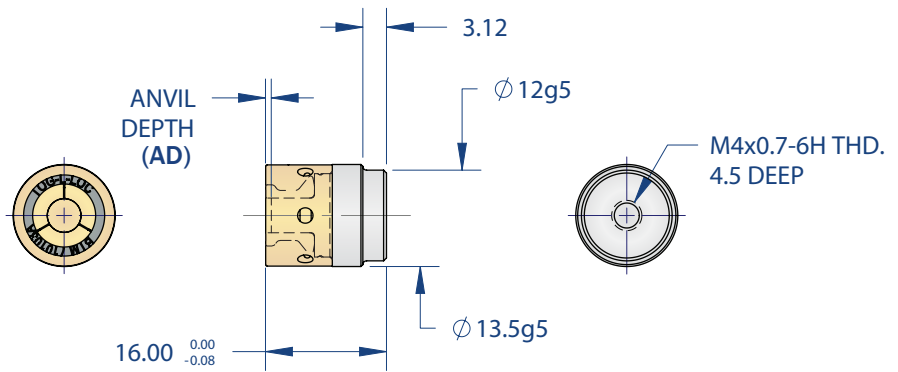

SSI Die Extensions

Length	Extension
40mm	796800A
60mm	796800B
80mm	796800C
100mm	796800D

ASSEMBLY INCLUDES:

- ① One (1) Extension
- ② One (1) Die Retaining Screw

NOT INCLUDED:

- ③ One (1) 3.8 "MINI" SSI Tog-L-Loc® Die
- ④ One (1) 940 Retaining Screw (BTM No. 018217)

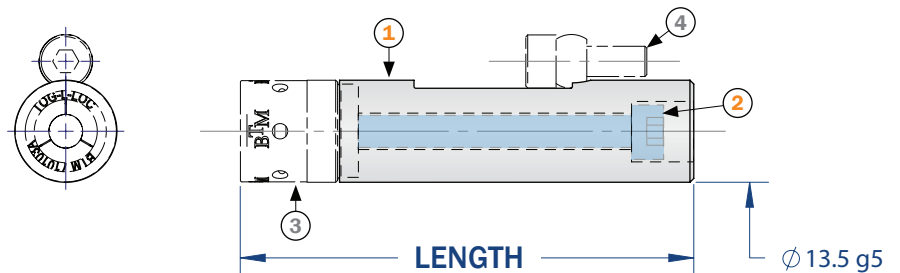

4.6 Tog-L-Loc® 940 Series “MINI” DIES

“Mini” dies are used when joining minimum flange widths and total material thickness permits joining with the maximum allowable button dimension (BD). Maximum BD for each mini die is stated.

“Mini” Style “A” die

AD	Standard
.020	710100BE
.025	710100CE
.030	710100DE
.035	710100EE
.040	710100FE
.045	710100GE

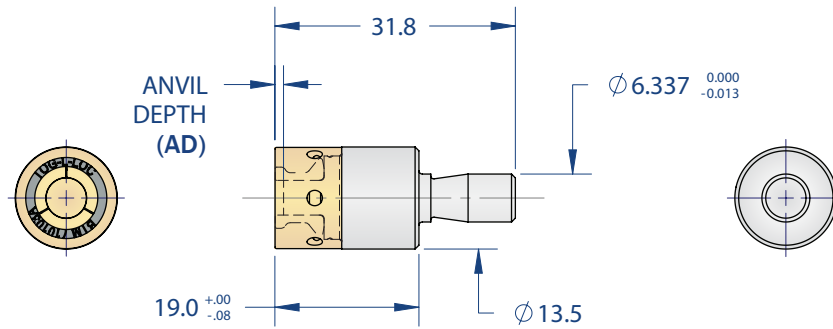

Contact BTM for the maximum total material thickness this die can join.
Maximum Button Diameter (BD) for this die is $\varnothing 7.11$

“Mini” Stepped Short Insert (SSI) die

AD	Standard
.020	751900BE
.025	751900CE
.030	751900DE
.035	751900EE
.040	751900FE
.045	751900GE

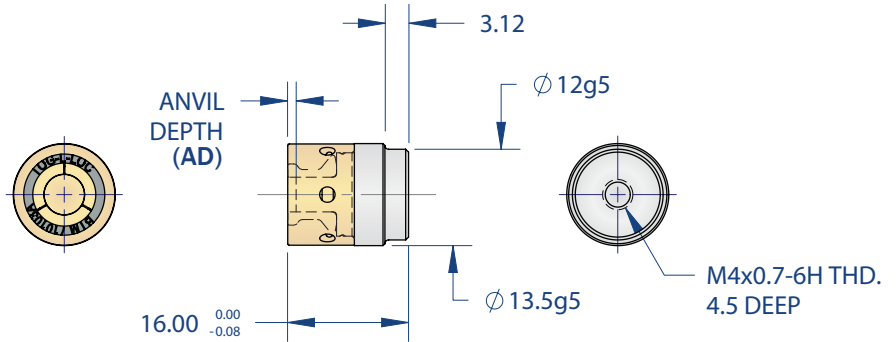

Contact BTM for the maximum total material thickness this die can join.
Maximum Button Diameter (BD) for this die is $\varnothing 7.11$

“Mini” SSI Die Extensions

Length	Extension
40mm	796800A
60mm	796800B
80mm	796800C
100mm	796800D

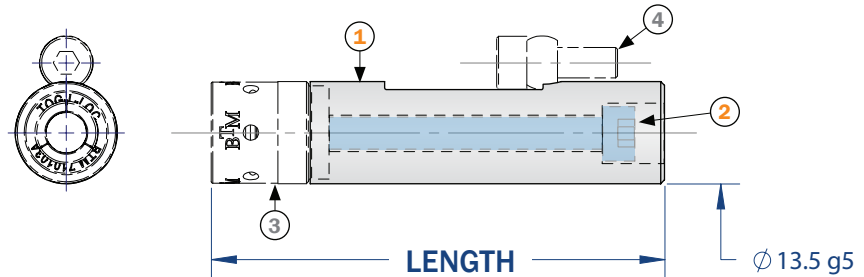

ASSEMBLY INCLUDES:

- ① One (1) Extension
- ② One (1) Die Retaining Screw

NOT INCLUDED:

- ③ One (1) 4.6 “MINI” SSI Tog-L-Loc® Die
- ④ One (1) 940 Retaining Screw (BTM No. 018217)

Style "A" die

AD	Standard	Aluminum
.020	716000BE	761700BE
.025	716000CE	761700CE
.030	716000DE	761700DE
.035	716000EE	761700EE
.040	716000FE	761700FE
.045	716000GE	761700GE
.050	716000HE	761700HE
.055	716000JE	761700JE
.060	716000KE	761700KE

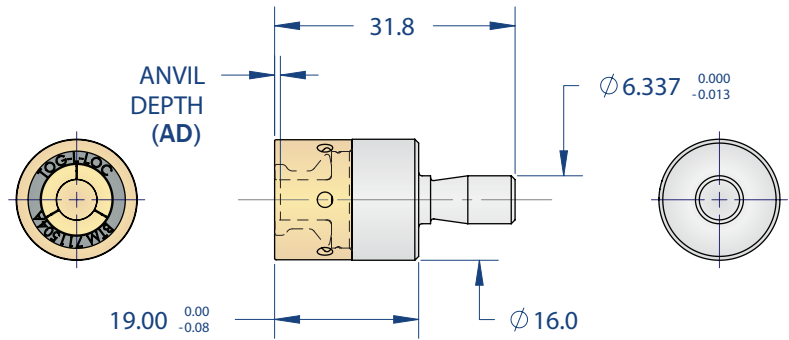

Stepped Short Insert (SSI) die

AD	Standard	Aluminum
.020	751100BE	793300BE
.025	751100CE	793300CE
.030	751100DE	793300DE
.035	751100EE	793300EE
.040	751100FE	793300FE
.045	751100GE	793300GE
.050	751100HE	793300HE
.055	751100JE	793300JE
.060	751100KE	793300KE

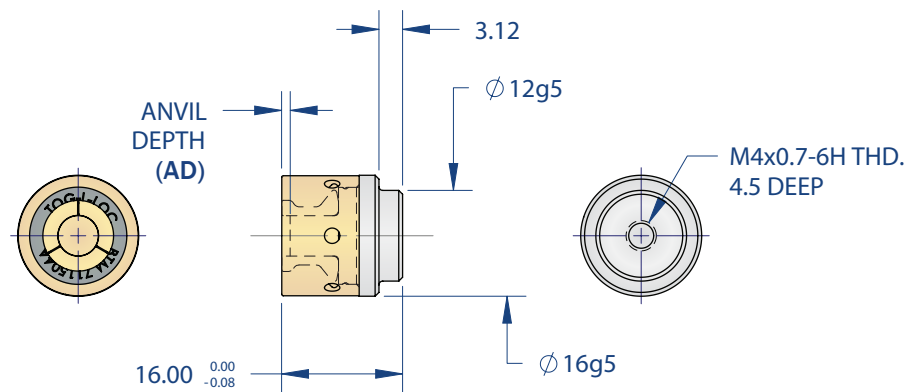

SSI Die Extensions

Length	Extension
60mm	PD220900B
80mm	PD220900C
100mm	PD220900D

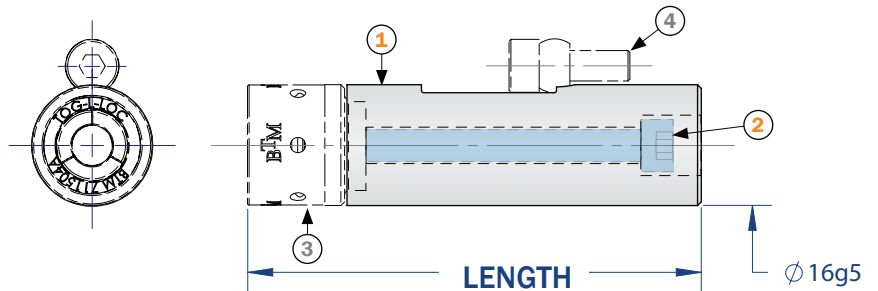

ASSEMBLY INCLUDES:

- ① One (1) Extension
- ② One (1) Die Retaining Screw

NOT INCLUDED:

- ③ One (1) 4.6 Tog-L-Loc® Die
- ④ One (1) 940 Retaining Screw (BTM No. 018217)

5.5 Tog-L-Loc® 940 Series “MINI” DIES

“Mini” dies are used when joining minimum flange widths and total material thickness permits joining with the maximum allowable button dimension (BD). Maximum BD for each mini die is stated.

“Mini” Style “A” die

AD	Standard
.025	767500BE
.030	767500CE
.035	767500DE
.040	767500EE
.045	767500FE
.050	767500GE
.055	767500HE

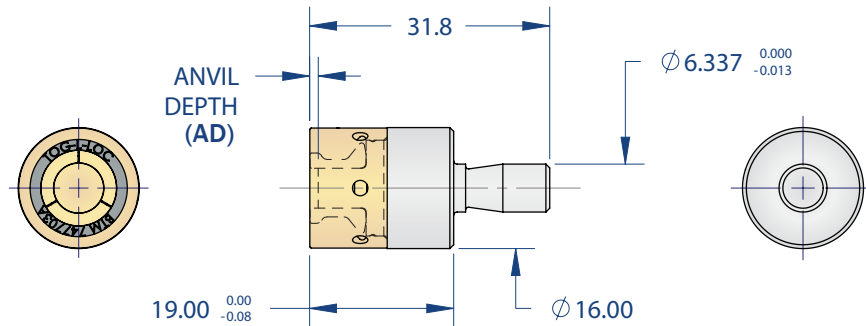

Contact BTM for the maximum total material thickness this die can join.
Maximum Button Diameter (BD) for this die is Ø8.64

“Mini” Stepped Short Insert (SSI) die

AD	Standard
.025	752000BE
.030	752000CE
.035	752000DE
.040	752000EE
.045	752000FE
.050	752000GE
.055	752000HE

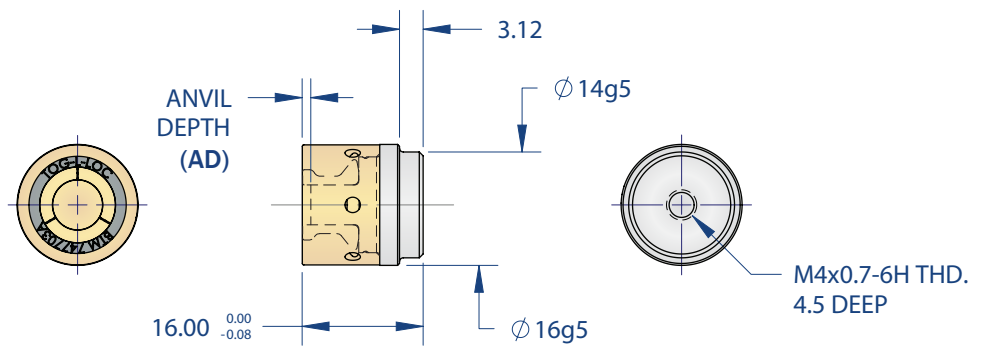

Contact BTM for the maximum total material thickness this die can join.
Maximum Button Diameter (BD) for this die is Ø8.64

“Mini” SSI Die Extensions

Length	Extension
60mm	PD220500B
80mm	PD220500C
100mm	PD220500D

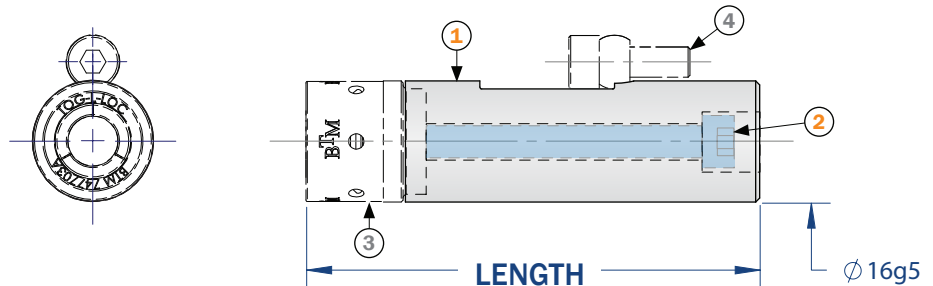

ASSEMBLY INCLUDES:

- ① One (1) Extension
- ② One (1) Die Retaining Screw

NOT INCLUDED:

- ③ One (1) 5.5 “MINI” SSI Tog-L-Loc® Die
- ④ One (1) 940 Retaining Screw (BTM No. 018217)

Style "A" die

AD	Standard	Aluminum
.025	742100BE	762100BE
.030	742100CE	762100CE
.035	742100DE	762100DE
.040	742100EE	762100EE
.045	742100FE	762100FE
.050	742100GE	762100GE
.055	742100HE	762100HE
.060	742100JE	762100JE
.065	742100KE	762100KE
.070	742100LE	762100LE

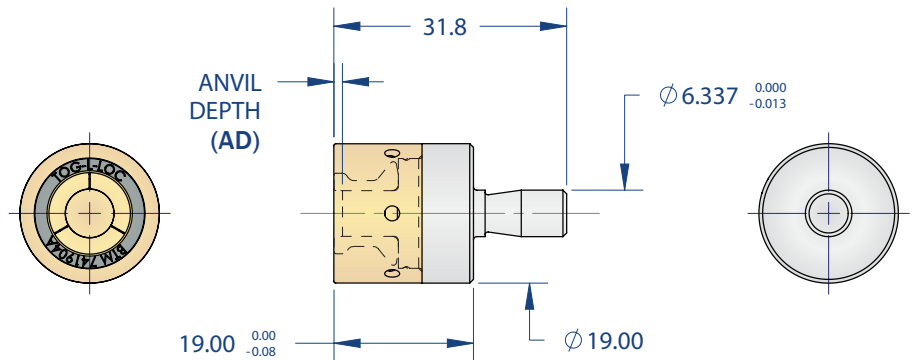

Stepped Short Insert (SSI) die

AD	Standard	Aluminum
.025	743400BE	779300BE
.030	743400CE	779300CE
.035	743400DE	779300DE
.040	743400EE	779300EE
.045	743400FE	779300FE
.050	743400GE	779300GE
.055	743400HE	779300HE
.060	743400JE	779300JE
.065	743400KE	779300KE
.070	743400LE	779300LE

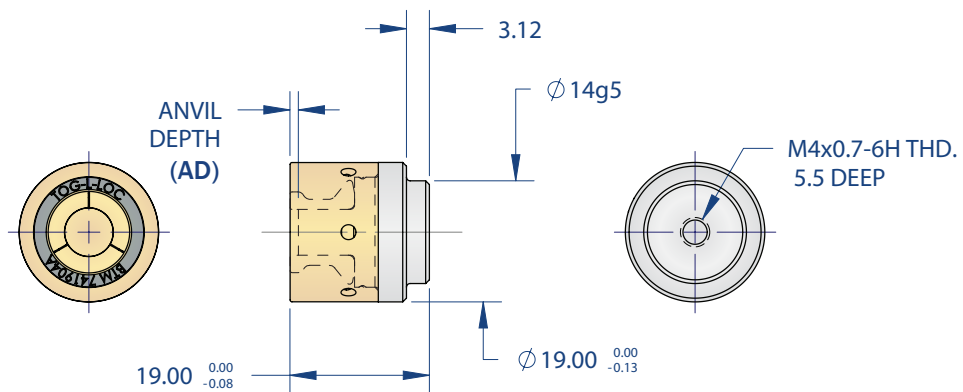

SSI Die Extensions

Length	Extension
60mm	PD220600B
80mm	PD220600C
100mm	PD220600D

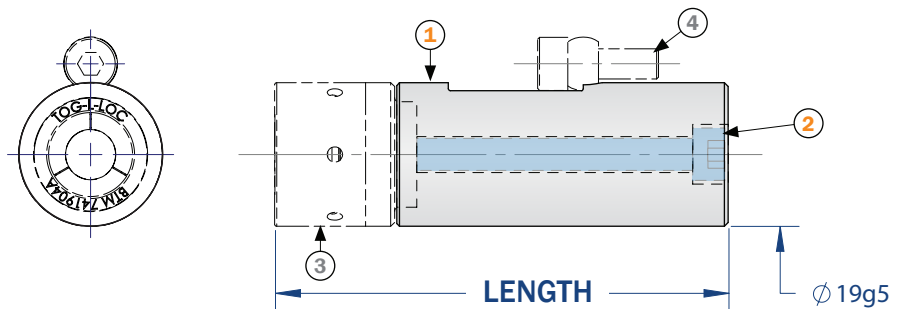

ASSEMBLY INCLUDES:

- ① One (1) Extension
- ② One (1) Die Retaining Screw

NOT INCLUDED:

- ③ One (1) 5.5 SSI Tog-L-Loc® Die
- ④ One (1) 940 Retaining Screw (BTM No. 018217)

6.4 Tog-L-Loc® 940 Series “MINI” DIES

“Mini” dies are used when joining minimum flange widths and total material thickness permits joining with the maximum allowable button dimension (BD). Maximum BD for each mini die is stated.

“Mini” Style “A” die

AD	Standard
.030	710900BE
.035	710900CE
.040	710900DE
.045	710900EE
.050	710900FE
.055	710900GE
.060	710900HE
.065	710900JE

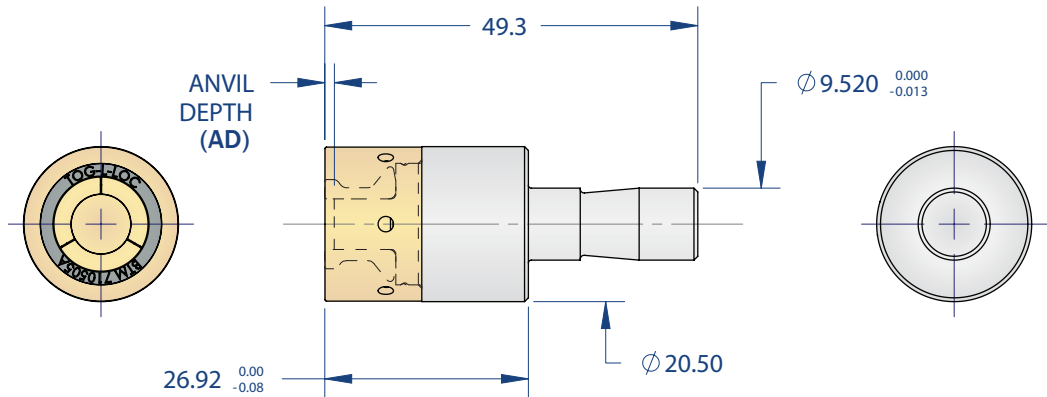

Contact BTM for the maximum total material thickness this die can join.
Maximum Button Diameter (BD) for this die is $\varnothing 10.16$

“Mini” Stepped Short Insert (SSI) die

AD	Standard
.030	752100BE
.035	752100CE
.040	752100DE
.045	752100EE
.050	752100FE
.055	752100GE
.060	752100HE
.065	752100JE

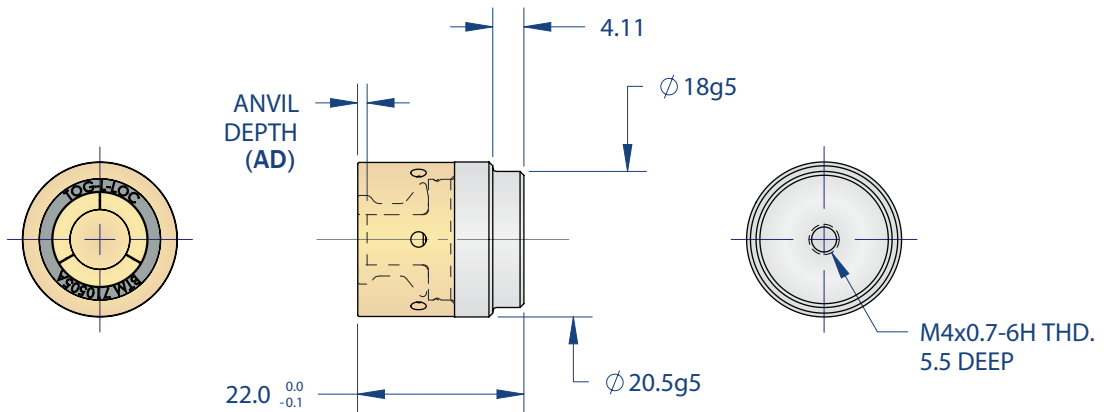

Contact BTM for the maximum total material thickness this die can join.
Maximum Button Diameter (BD) for this die is $\varnothing 10.16$

“Mini” SSI Die Extensions

Length	Extension
60mm	PD214700B
80mm	PD214700C
100mm	PD214700D

ASSEMBLY INCLUDES:

- ① One (1) Extension
- ② One (1) Die Retaining Screw

NOT INCLUDED:

- ③ One (1) 6.4 “MINI” SSI Tog-L-Loc® Die
- ④ One (1) 940 Retaining Screw (BTM No. 023228)

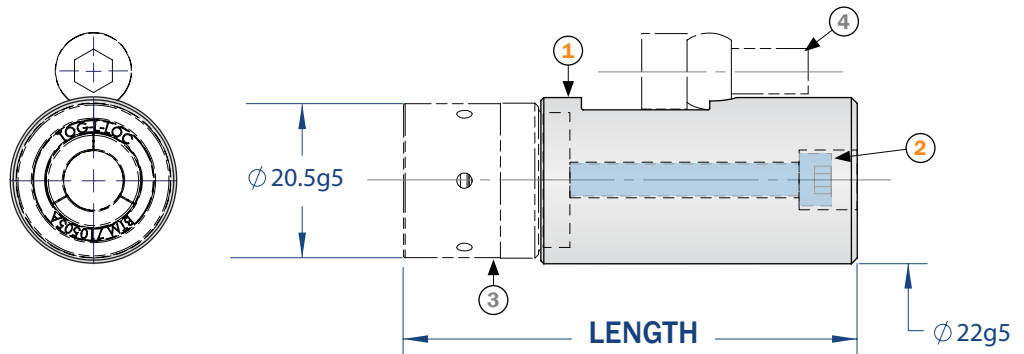

Style "A" die

AD	Standard	Aluminum
.030	744700BE	744800BE
.035	744700CE	744800CE
.040	744700DE	744800DE
.045	744700EE	744800EE
.050	744700FE	744800FE
.055	744700GE	744800GE
.060	744700HE	744800HE
.065	744700JE	744800JE
.070	744700KE	744800KE
.075	744700LE	744800LE
.080	744700ME	744800ME

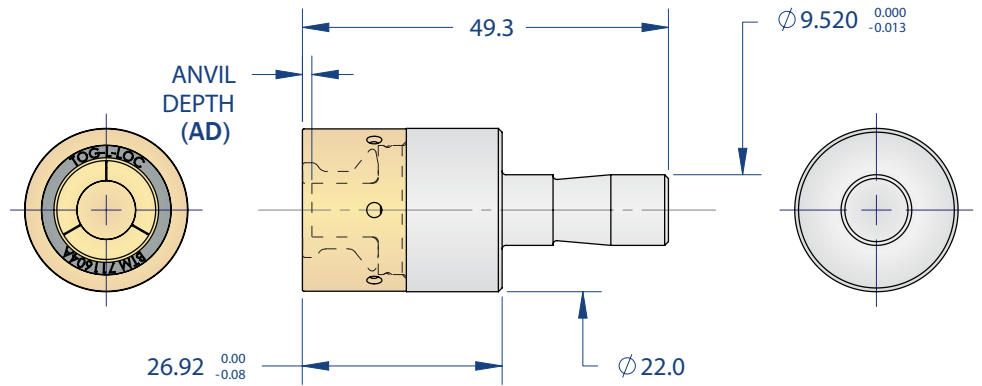

Stepped Short Insert (SSI) die

AD	Standard	Aluminum
.030	751200BE	779400BE
.035	751200CE	779400CE
.040	751200DE	779400DE
.045	751200EE	779400EE
.050	751200FE	779400FE
.055	751200GE	779400GE
.060	751200HE	779400HE
.065	751200JE	779400JE
.070	751200KE	779400KE
.075	751200LE	779400LE
.080	751200ME	779400ME

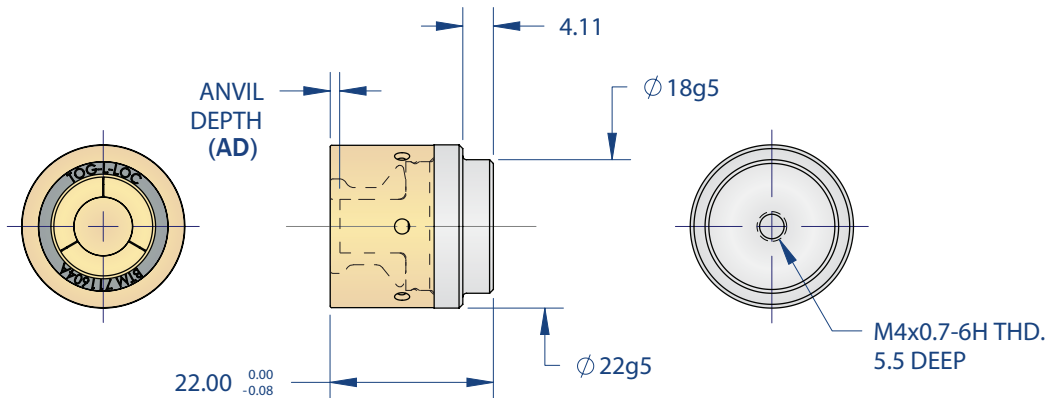

SSI Die Extensions

Length	Extension
60mm	PD214700B
80mm	PD214700C
100mm	PD214700D

- ASSEMBLY INCLUDES:**
- ① One (1) Extension
 - ② One (1) Die Retaining Screw
- NOT INCLUDED:**
- ③ One (1) 6.4 SSI Tog-L-Loc® Die
 - ④ One (1) 940 Retaining Screw (BTM No. 023228)

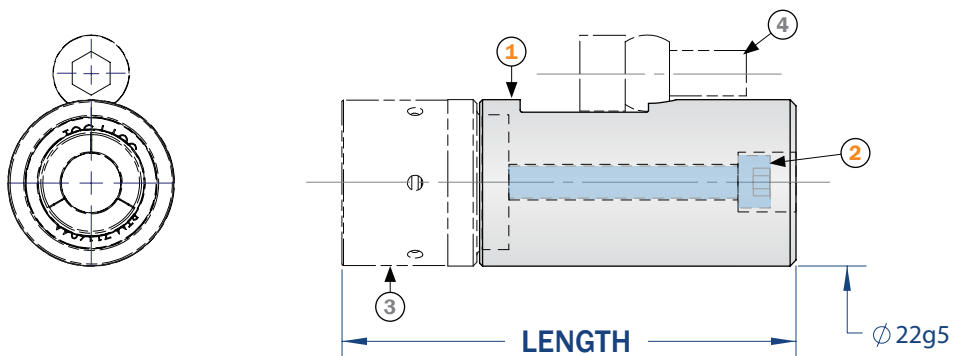

7.6 Tog-L-Loc® 940 Series “MINI” DIES

“Mini” dies are used when joining minimum flange widths and total material thickness permits joining with the maximum allowable button dimension (BD). Maximum BD for each mini die is stated.

“Mini” Stepped Short Insert (SSI) die

AD	Standard
.035	767700B
.040	767700C
.045	767700D
.050	767700E
.055	767700F
.060	767700G
.065	767700H
.070	767700J
.075	767700K
.080	767700L
.085	767700M
.090	767700N

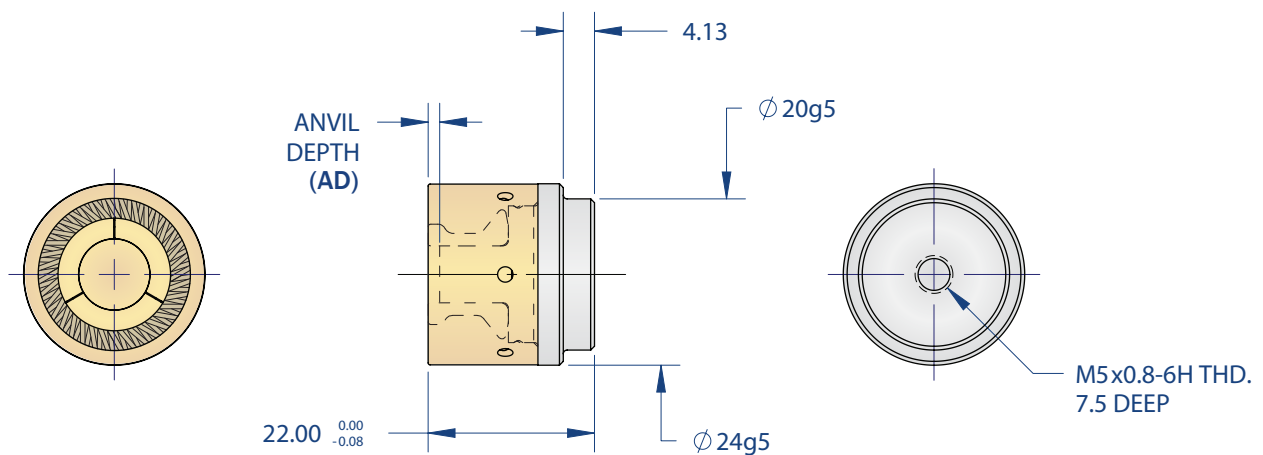

NOTE: Elastomeric rings are not available for 7.6 MINI dies. This die utilizes a canted coil spring.

Contact BTM for the maximum total material thickness this die can join.
Maximum Button Diameter (BD) for this die is Ø12.50

“MINI” SSI Die Extensions - Same as Regular 7.6 SSI Extensions (See p. 23)

Stepped Short Insert (SSI) die

AD	Standard
.045	779600BE
.050	779600CE
.055	779600DE
.060	779600EE
.065	779600FE
.070	779600GE
.075	779600HE
.080	779600JE
.085	779600KE
.090	779600LE
.095	779600ME
.100	779600NE

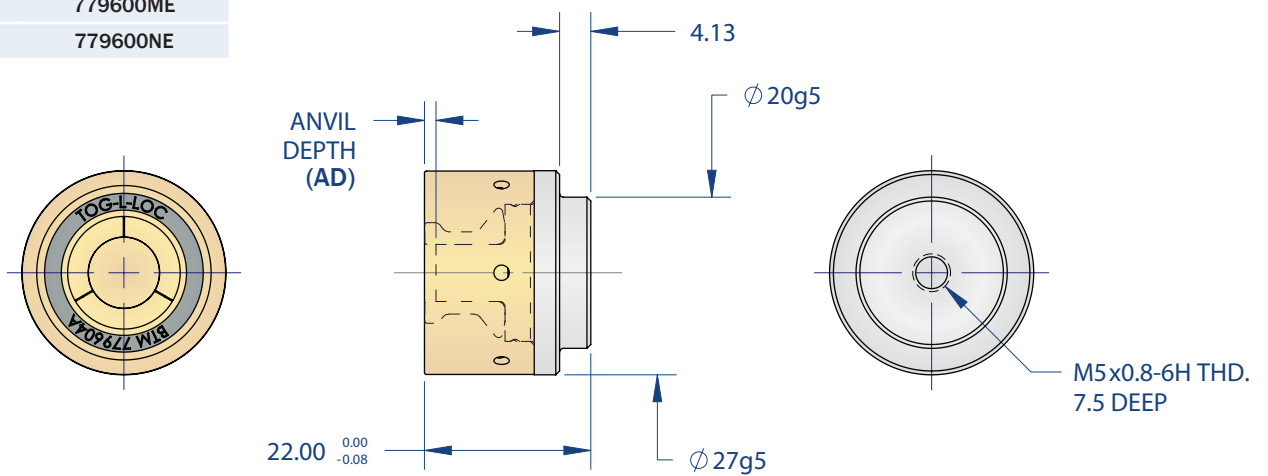

SSI Die Extensions

Length	Extension
60mm	PD220700B
80mm	PD220700C
100mm	PD220700D

ASSEMBLY INCLUDES:

- ① One (1) Extension
- ② One (1) Die Retaining Screw

NOT INCLUDED:

- ③ One (1) 7.6 "MINI" or Regular SSI Tog-L-Loc® Die
- ④ One (1) 940 Retaining Screw [BTM No. 023228]

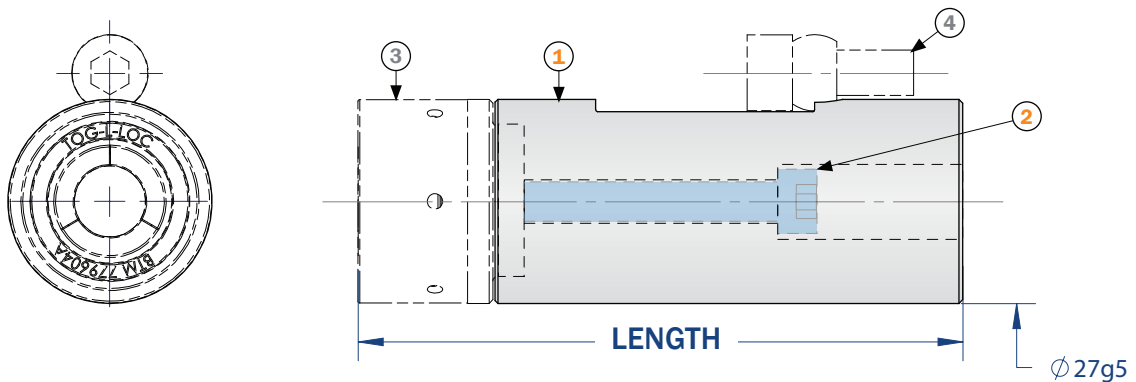

Thin Die Holder - For 940 series SSI dies with a 40-100mm extension.

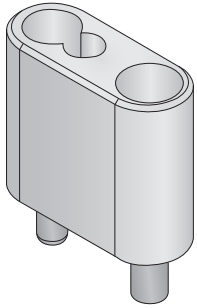

ASSEMBLY INCLUDES:

- ① One (1) Die Holder
- ② One (1) Mounting Screw
- ③ One (1) Die Retaining Screw Assembly
- ④ One (1) Dowel Pin

NOT INCLUDED

- ⑤ One (1) SSI Die w/ Extension

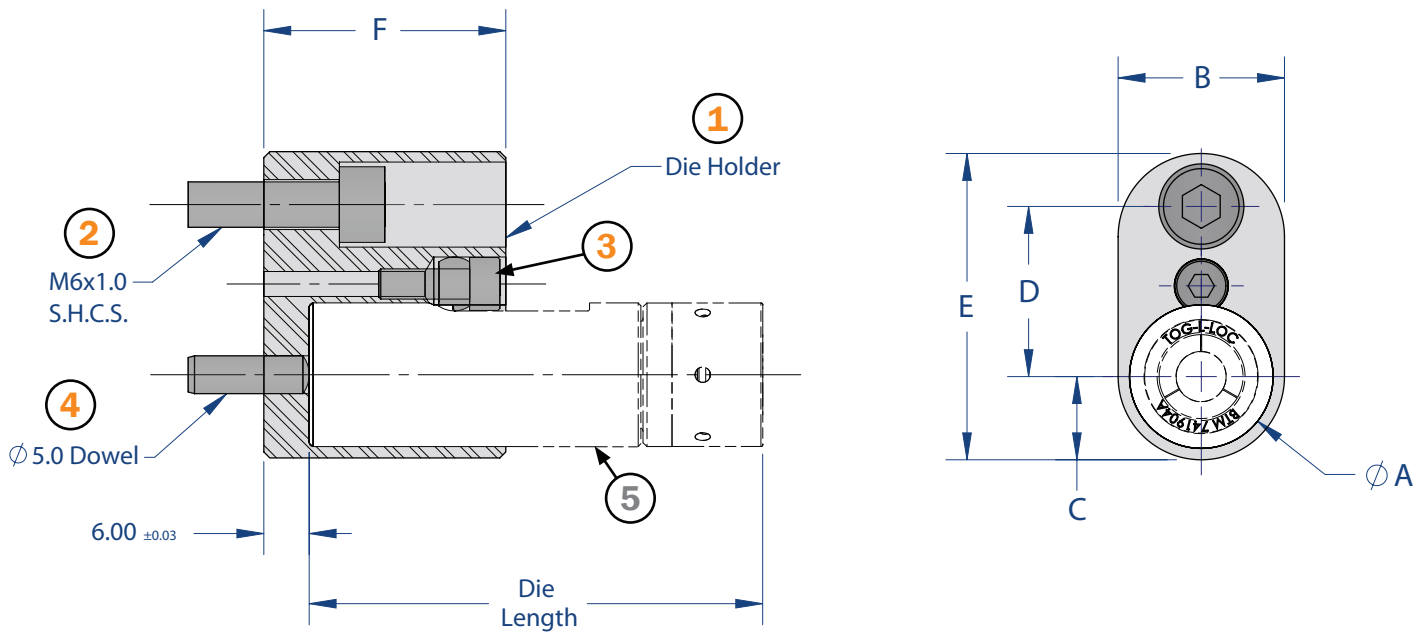

Tooling Size		A	B	C	D	E	F	BTM No.
STD.	"MINI"							
3.0	3.0, 3.8	Ø12H6mm	15.0	7.5	22.5	37.0	32.0	737400A
3.8	4.6	Ø13.5H6mm	16.5	8.3	22.5	37.8	32.0	PD250100A
4.6	5.5	Ø16H6mm	19.0	9.5	22.5	39.0	32.0	737400C
5.5	—	Ø19H6mm	22.0	11.0	22.5	40.5	32.0	737400H
6.4	6.4	Ø22H6mm	25.0	12.5	25.0	44.6	35.0	PD214900A

“940” Series Die Retention

The location tolerance to the centerline of the die hole should be $\pm 0.013\text{mm}$.

940 Series dies require a knock out hole from the back side.

Because the 940 die has a built in blade shield, the top of the die should not be flush with the detail it's mounted in. If anvil strength is not an issue, the typical design method would expose the ring of small holes in the guard can.

Stepped Short Insert [SSI] Die Mounting

For all Tog-L-Loc® joint sizes

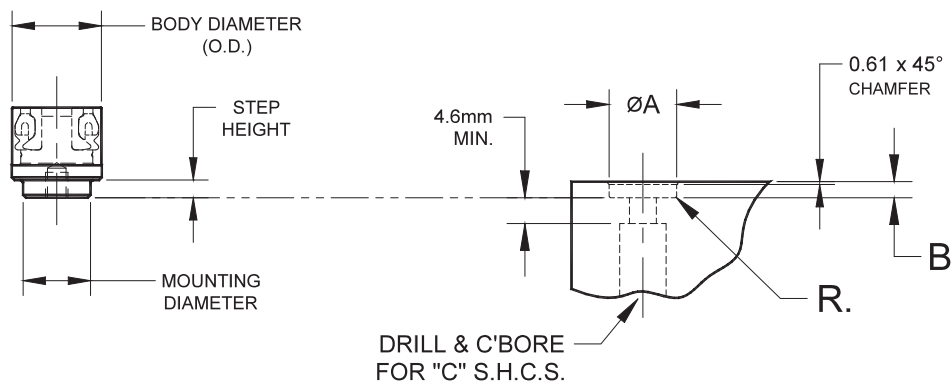

Tooling Size	A	B	C	R
3.0 "MINI"	Ø8H6mm	2.24 ± 0.13	M4x0.7	—
3.0	Ø8H6mm	2.24 ± 0.13	M4x0.7	—
3.8 "MINI"	Ø10H6mm	2.84 ± 0.13	M4x0.7	R0.25 MAX
3.8	Ø12H6mm	2.84 ± 0.13	M4x0.7	R0.25 MAX
4.6 "MINI"	Ø12H6mm	2.84 ± 0.13	M4x0.7	R0.25 MAX
4.6	Ø12H6mm	2.84 ± 0.13	M4x0.7	R0.33 ± 0.13
5.5 "MINI"	Ø14H6mm	2.84 ± 0.13	M4x0.7	R0.33 ± 0.13
5.5	Ø14H6mm	2.84 ± 0.13	M4x0.7	R0.33 ± 0.13
6.4 "MINI"	Ø18H6mm	3.84 ± 0.13	M4x0.7	R0.33 ± 0.13
6.4	Ø18H6mm	3.84 ± 0.13	M4x0.7	R0.33 ± 0.13
7.6 "MINI"	Ø20H6mm	3.84 ± 0.13	M5x0.8	R0.36 ± 0.13
7.6	Ø20H6mm	3.84 ± 0.13	M5x0.8	R0.36 ± 0.13

Style "A" Die Mounting

For 3.0, 3.8, 4.6, & 5.5 Tog-L-Loc® joints.

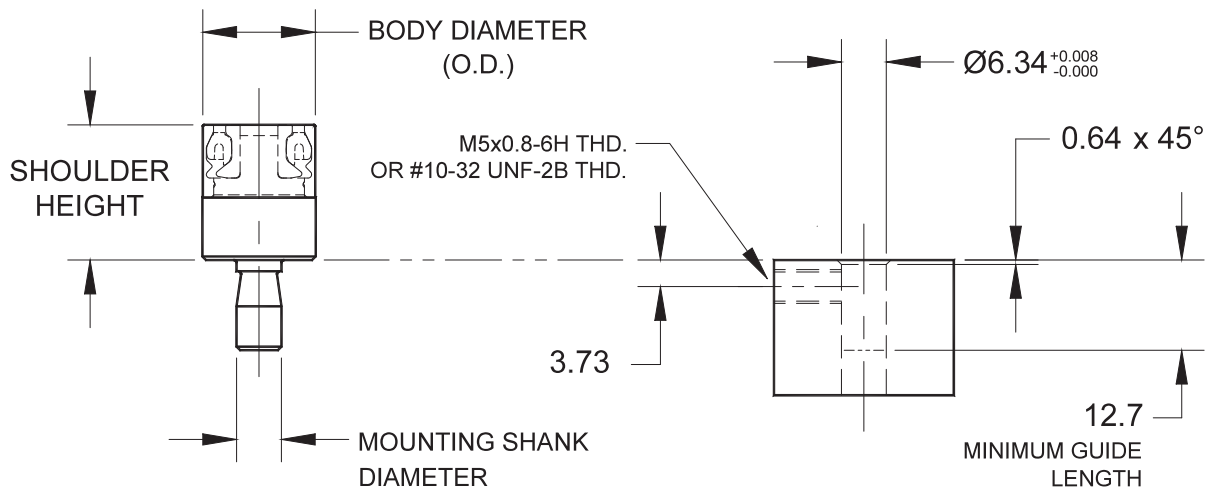

Style "A" Die Mounting

For 6.4 Tog-L-Loc® joints.

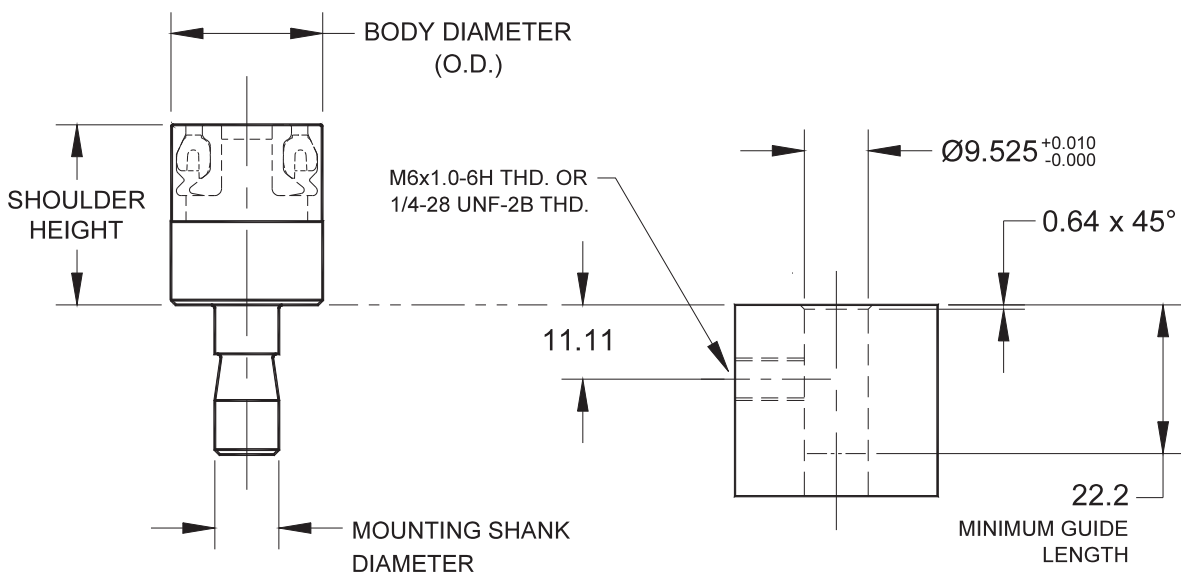

BTM[®]

EUROPE

BTM has a wide range of products for applying Tog-L-Loc[®] tooling including:

Press Brakes



BTM's unitized press brake tooling is a low cost way to utilize the patented Tog-L-Loc[®] sheet metal joining system and is available with a wide range of throat depths. The units are set up for a specified metal combination, and are ready to install into your brake.

Die Sets



Tog-L-Loc[®] tooling can be inexpensively designed into single or compound motion die set packages.

Handheld Units



BTM's handheld units are an economical approach to fastening sheet metal assemblies. Pneumatic, Hydraulic, and Self-Contained Units in a variety of styles are available. The units can be set up to join a range of thicknesses or optimized for a specific metal thickness.

Special Fixtures



Manually loaded and unloaded dedicated tooling can be built for a single part or a family of parts.

Universal Presses



Universal presses are hydraulically operated presses that easily adapt to join a variety of parts.

Special Systems



Achieve faster cycle times with automatic parts handling and/or by combining processes.

Specialized Units



BTM provides pneumatic, hydraulic, air/oil, and electrically driven units with single or dual motions for both stationary and robotic applications.

For more information, or to see our full line of products, please visit:

WWW.BTM-EUROPE.DE